

January 7, 1974

Mr. Max Bell
Permanent Salary and Sabbatical Leave Committee
Mt. San Antonio College

Dear Mr. Bell:

In response to your request for further information about my sabbatical project for the '72-'73 school year, I am enclosing a copy of the sketches I have done for the 120 illustrations to be included in the preliminary copy of the book, Physics for Inhalation Therapy Students, which constituted my project. A bibliography of part of the references used is also enclosed; periodicals, U. S. Government publications, encyclopedia, and company publications are not included. Basic physics texts seldom contain complete bibliographies; if there is a real need for a complete listing, I can compile one from my working notes.

A copy of my sabbatical request plan should be available to you in the President's Office. The course at Harvey Mudd College was not part of the original request--I mentioned it only as an example of the advantage of time flexibility during a sabbatical and because the course work I did related to the book I was working on. The course required four full school days of attendance, which would not have been possible for me during a normal school year. During the course on mathematical models, I worked out a fluid flow model for use in our physics lab programmable computer. The results can be used to demonstrate for inhalation therapy students how changing different variables affects fluid flow. The course was sponsored by the National Science Foundation which furnished certificates to the participants, but the course was not graded.

My library research was conducted chiefly in the Mt. San Antonio College and California State Polytechnic University libraries.

At the present time, I am going over my book with some former students who are working in the inhalation therapy field and who are preparing to take the registry examinations in that field in March. Since I designed

the book specifically to cover the topics which form the physics background in this field, I hope to make use of any suggestions of the therapists to improve the book and hope they will benefit from using it.

Next fall I plan to use material from the revised version in teaching the inhalation therapy physics courses and to try out problem sets and chapter review sections to be included. Altogether I will probably be working another year on revisions.

I hope the final result will be a useful text covering the physics background needed for inhalation therapy in a manner which is not available in other texts. This year I am not teaching the inhalation therapy physics course as originally planned, so I have not had an opportunity to use the special topics contained in Chapters 6 through 9; however, other parts of the material are useful in the courses which I am teaching (general physics and an allied health physics course for radiological technicians).

Sincerely,

Mavis L. McCormic

Mavis L. McCormic

BIBLIOGRAPHY
FOR
PHYSICS FOR INHALATION THERAPY STUDENTS

1. Ander, Paul, and Sonnessa, Anthony J., Principles of Chemistry: An Introduction to Theoretical Concepts, New York: Macmillan Co., 1965.
2. Bachmann, Charles H., Physics: Understanding Our Physical Environment, Croton-on Hudson, New York: Bogden & Quigley, Inc., Publishers, 1970.
3. Baez, Albert V., The New College Physics: A Spiral Approach, San Francisco: W. H. Freeman and Company, 1967.
4. Beiser, Albert V., Concepts of Modern Physics, New York: McGraw-Hill Book Company, Inc., 1967.
5. Carlin, Benson, Ultrasonics, 2nd ed., New York: McGraw-Hill Book Company, Inc., 1960.
6. Egan, Donald F., Fundamentals of Inhalation Therapy, Saint Louis: The C. V. Mosby Company, 1969.
7. Fenn, Wallace, and Rahn, Hermann (ed.), Handbook of Physiology Section 3: Respiration, Vol. I, Washington, D.C.: American Physiological Society, 1964.
8. Fenn, Wallace, and Rahn, Hermann (ed.), Handbook of Physiology Section 3: Respiration, Vol. II, Washington, D.C.: American Physiological Society, 1965.
9. Ference, Michael, Jr., Lemon, Harvey B., Stephenson, Reginald J., Analytical Experimental Physics, 2nd ed. revised, Chicago: University of Chicago Press, 1956.

10. Feynman, Richard, Leighton, Robert B., and Sands, Matthew, The Feynman Lectures on Physics: Mainly Mechanics, Radiation, and Heat, Vol. I, Reading, Mass.: Addison-Wesley Publishing Co., 1963.
11. Feynman, Richard, Leighton, Robert B., and Sands, Matthew, The Feynman Lectures on Physics: Mainly Electromagnetism and Matter, Vol. II, Reading, Mass.: Addison-Wesley Publishing Co., 1964.
12. Giles, Ranald V., Schaum's Outline of Theory and Problems of Hydraulics and Fluid Mechanics, New York: Schaum Publishing Co., 1956.
13. Glasser, Otto (ed.), Medical Physics, Vol. I, Chicago: The Year Book Publishers, Inc., 1944.
14. Glasser, Otto (ed.), Medical Physics, Vol. II, Chicago: The Year Book Publishers, Inc., 1950.
15. Glasser, Otto (ed.), Medical Physics, Vol. III, Chicago: The Year Book Publishers, Inc., 1960.
16. Halacy, Daniel S., Jr., Bionics, New York: Holiday House, 1965.
17. Halliday, David, and Resnick, Robert, Fundamentals of Physics, New York: John Wiley & Sons, Inc., 1970.
18. Kip, Arthur F., Fundamentals of Electricity and Magnetism, New York: McGraw-Hill Book Company, Inc., 1962.
19. Korsunky, M., The Atomic Nucleus, New York: Dover Publications, Inc., 1963.

20. Liepmann, H. W., and Rosko, A., Elements of Gasdynamics, New York: John Wiley & Sons, Inc., 1957.
21. Miller, Franklin, Jr., College Physics 3rd ed., New York: Harcourt Brace Jovanovich, Inc., 1972.
22. Ruch, Theodore C., and Fulton, John F. (ed.), Medical Physiology and Biophysics, 18th ed., Philadelphia and London: W. B. Saunders Co., 1960.
23. Sears, Francis Weston, An Introduction to Thermodynamics, the Kinetic Theory of Gases, and Statistical Mechanics, 2nd ed., Reading, Mass.: Addison-Wesley Publishing Co., Inc., 1959.
24. Sears, Francis Weston, Mechanics, Heat, and Sound, 2nd ed, Reading, Mass.: Addison-Wesley Publishing Co., Inc., 1958.
25. Stacy, Ralph W., Williams, David T., Worden, Ralph E., and McMorris, Rex O., Essentials of Biological and Medical Physics, New York: McGraw-Hill, 1955.
26. Tilley, Donald E., and Thumm, Walter, College Physics: A Text with Applications to the Life Sciences, Menlo Park, California, 1971.
27. Tilley, Donald E., and Thumm, Walter, Physics in Medicine: A Supplement to College Physics, Menlo Park, California, 1972.
28. Tipler, Paul A., Foundations of Modern Physics, New York: Worth Publishers, Inc., 1969.
29. Vennard, John K., Elementary Fluid Mechanics, 3rd ed., New York: John Wiley & Sons, Inc., 1954.

CHAPTER 1 ILLUSTRATIONS

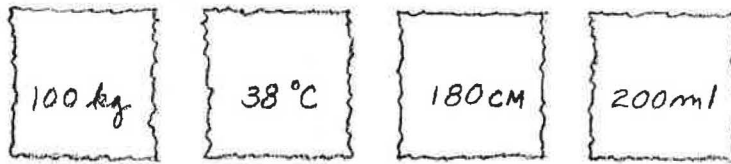

1-1 AUSTRALIAN METRIC STAMPS (PHOTO).

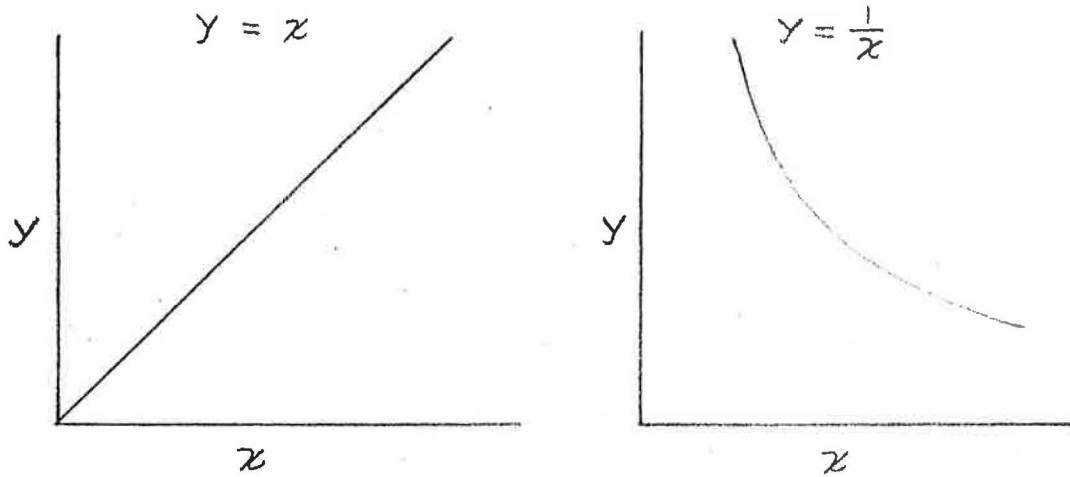

1-2. PLOTS OF y AS A FUNCTION OF x .

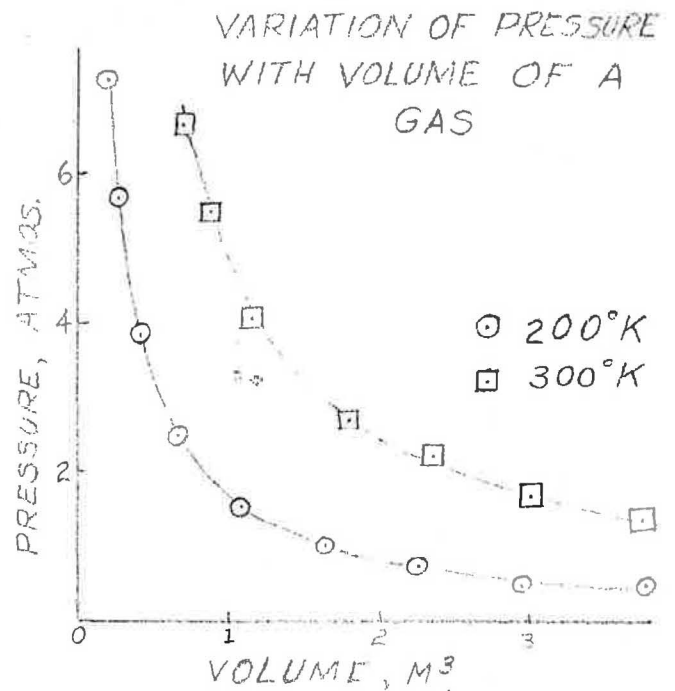
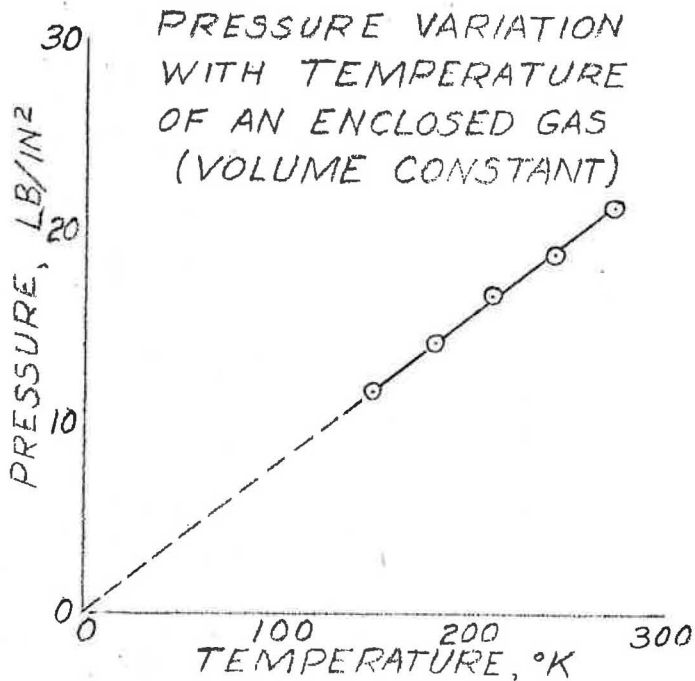

1-3. PLOTS OF EXPERIMENTAL DATA.

VECTOR REPRESENTING
A VELOCITY OF 50 MI/HR NE

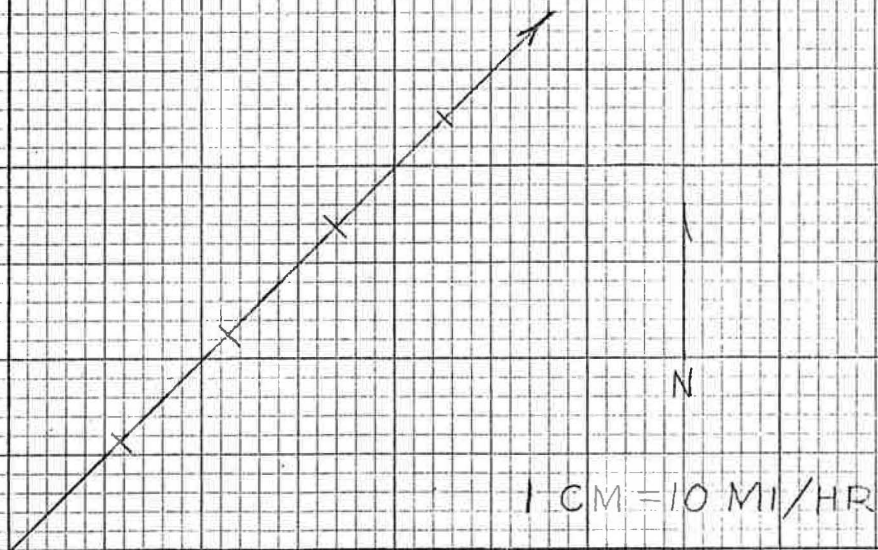

FIGURE 2-1 (a)

VELOCITY VECTOR REPRESENTING 50 MI/HR NE

FORCE OF 4 LB 30°
COUNTERCLOCKWISE
FROM 8-LB FORCE

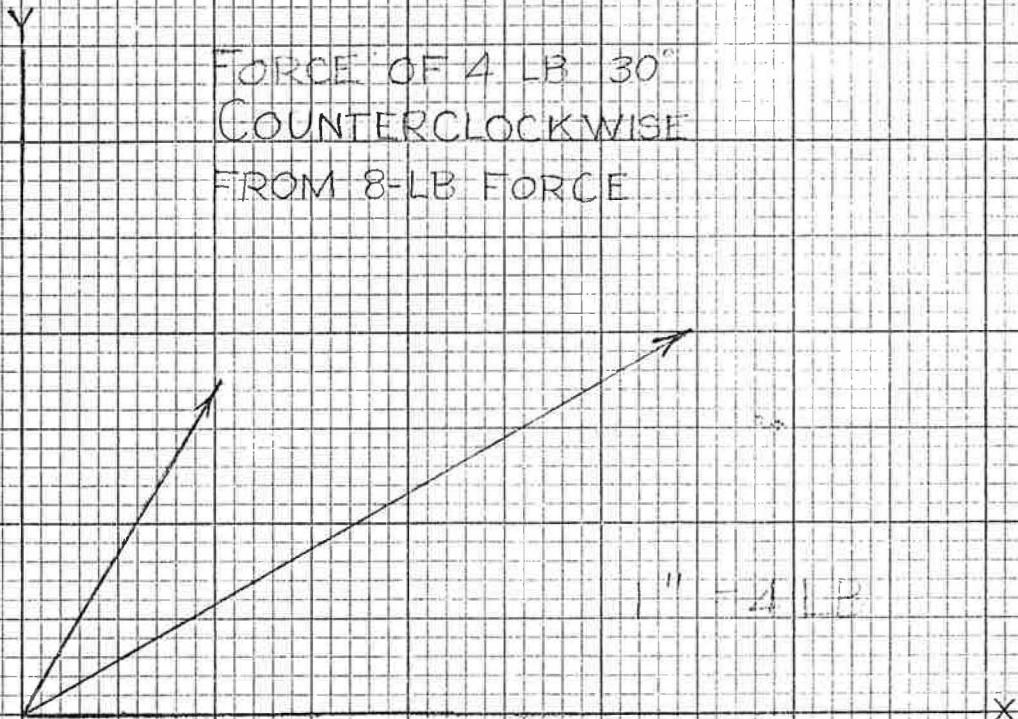

FIGURE 2-1 (b)

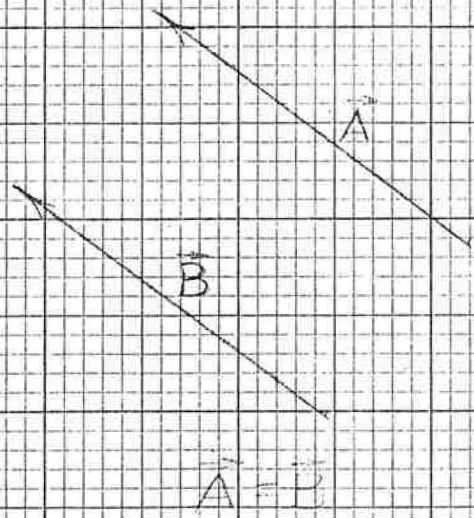
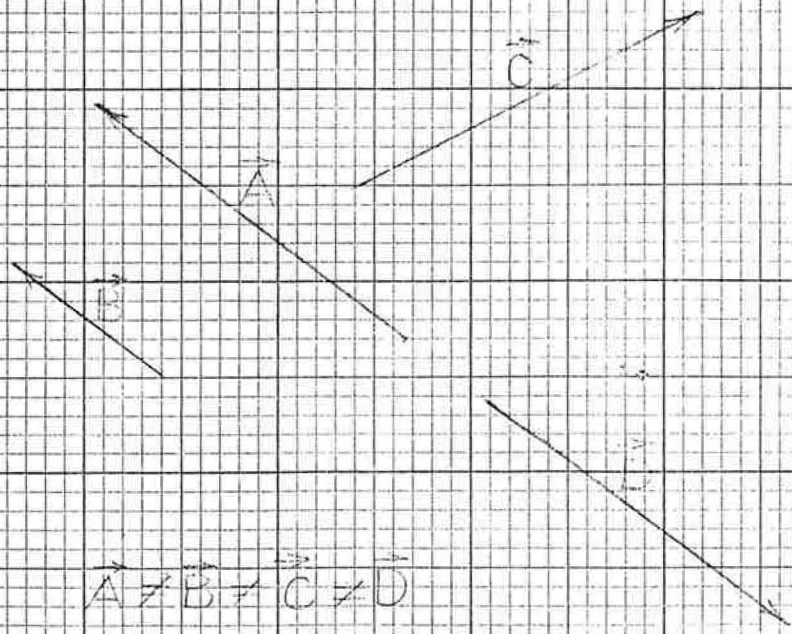
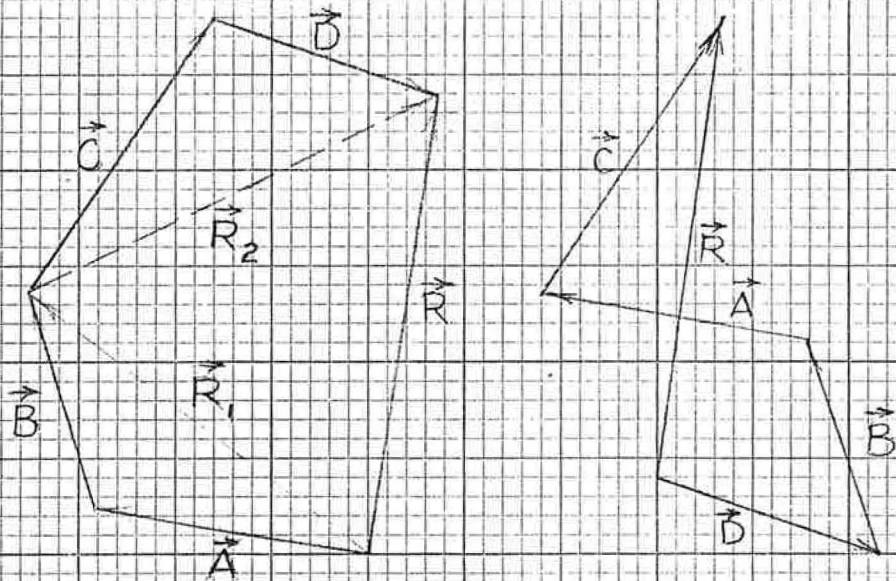

FIGURE 2-2 (a)
EQUAL VECTORS



$$\vec{A} \neq \vec{B} \neq \vec{C} \neq \vec{D}$$

FIGURE 2-2 (b)
UNEQUAL VECTORS



(a) $\vec{A} + \vec{B} + \vec{C} + \vec{D} = \vec{R}$

(b) $\vec{D} + \vec{B} + \vec{A} + \vec{C} = \vec{R}$

FIGURE 2-4
POLYGON VECTOR ADDITION

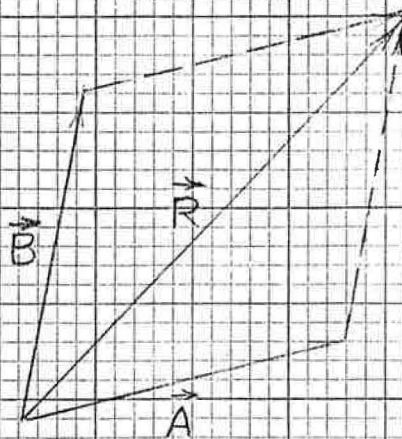

$\vec{A} + \vec{B} = \vec{R}$

FIGURE 2-5
PARALLELOGRAM VECTOR ADDITION

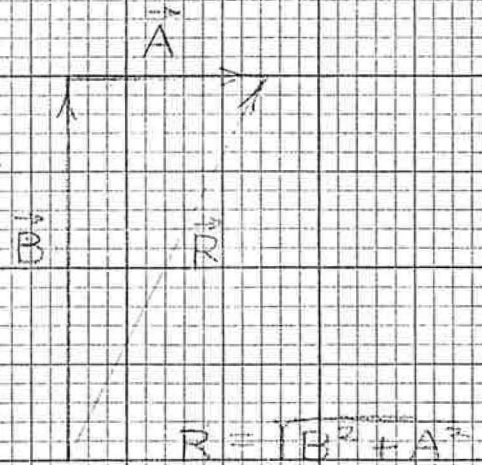
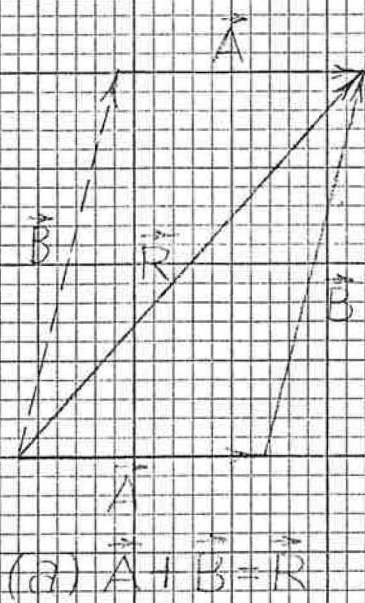

(b) ADDITION OF VECTORS 90° APART

FIGURE 2-3

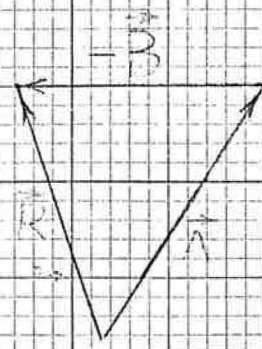
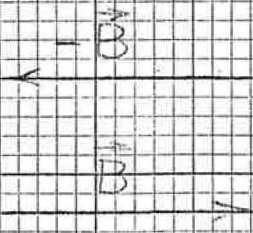

(a) $-\vec{B} = -(\vec{B})$

(b) $\vec{R} = \vec{A} - \vec{B}$

FIGURE 2-6
 VECTOR SUBTRACTION

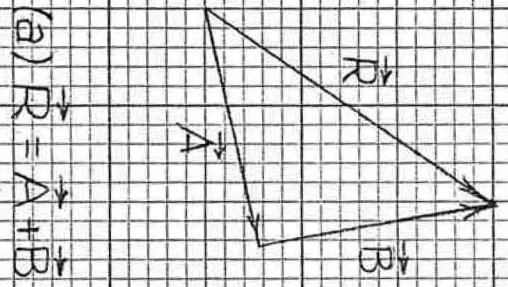

(a) $\vec{R} = \vec{A} + \vec{B}$

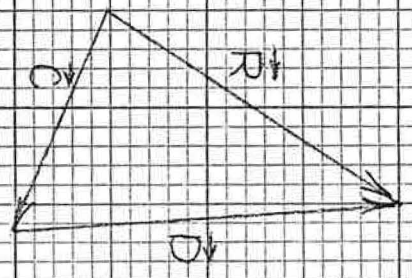

(b) $\vec{R} = \vec{C} + \vec{D}$

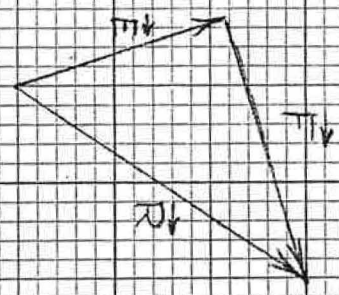

(c) $\vec{R} = \vec{E} + \vec{F}$

FIGURE 2-7
RESOLUTION OF A VECTOR

VARIATION OF SPEED WITH TIME
 FOR CONSTANT ACCELERATION

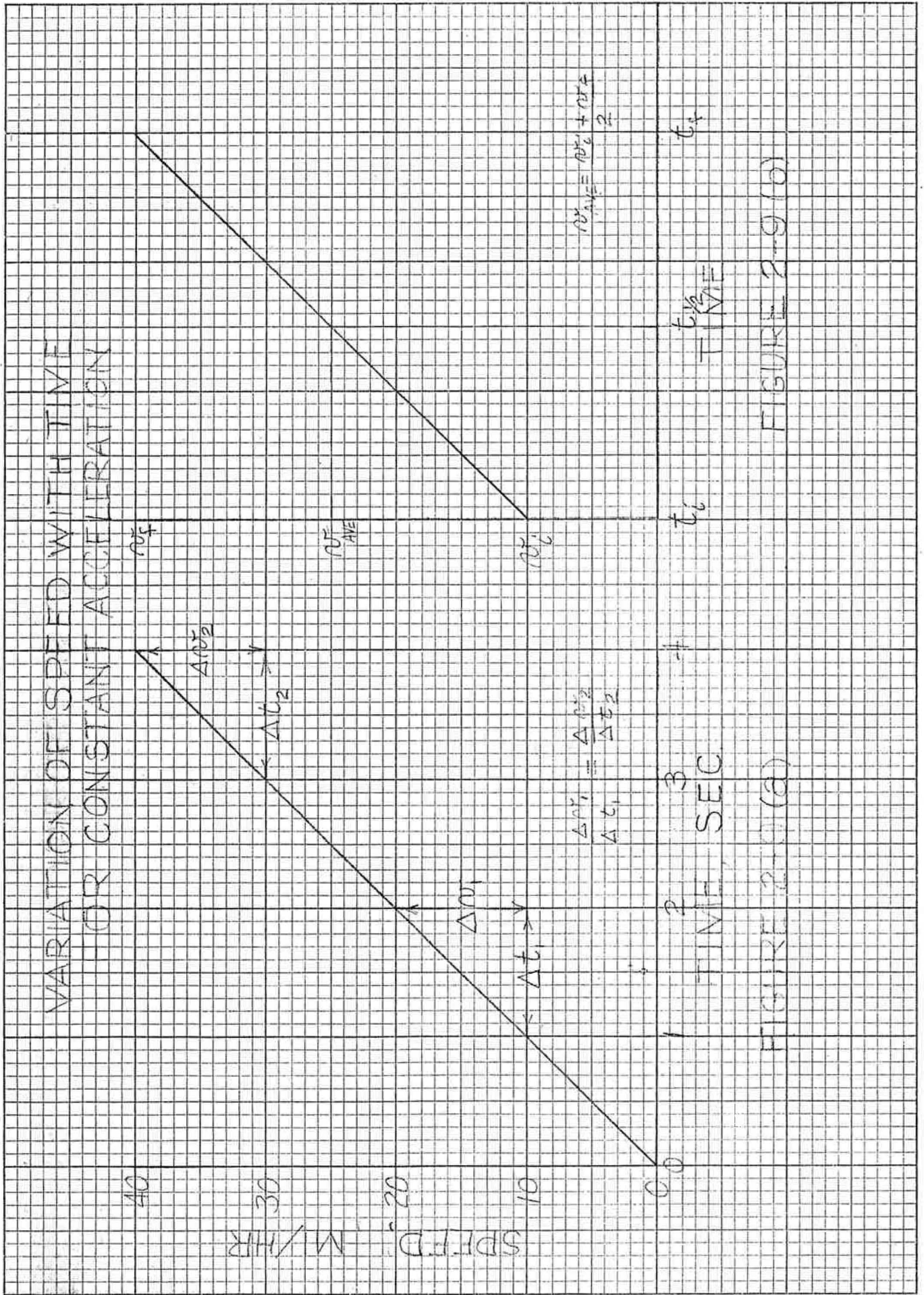

FIGURE 2-9 (b)

K&E
1/2 X 10 INCHES
KENTLETT & ESSER CO.
MADE IN U.S.A.
48 0185

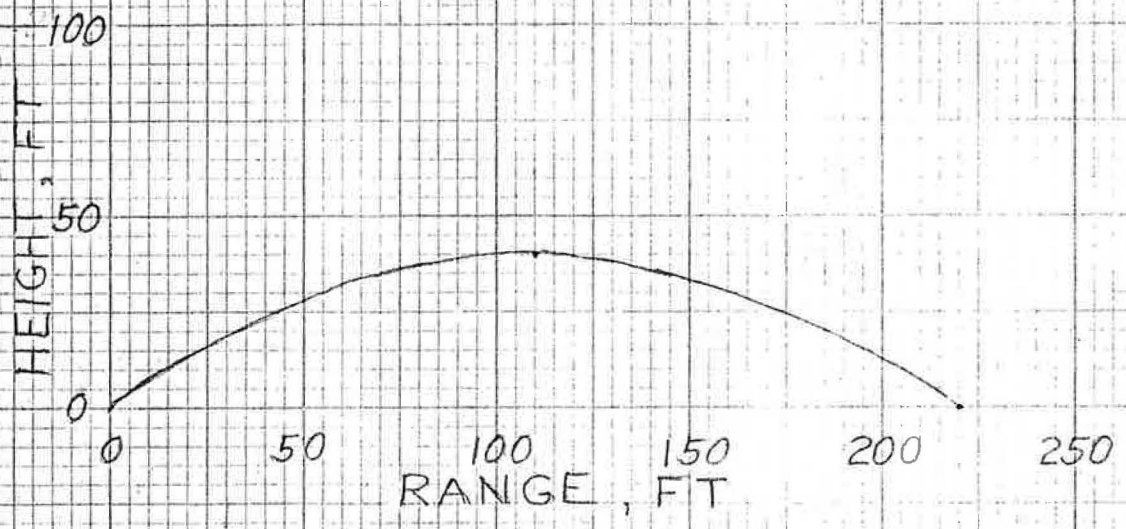

FIGURE 2-8(a) PROJECTILE PATH

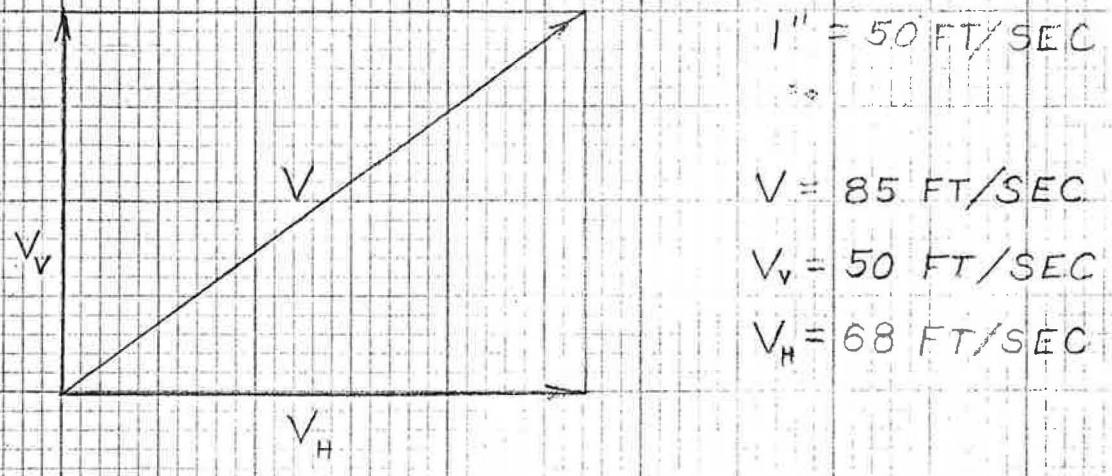

FIGURE 2-8(b) VECTOR RESOLUTION

CHAP. 2 ILLUS. (CONT.)



(a) TOP VIEW SHOWING HORIZONTAL MOTION.



(b) END VIEW SHOWING VERTICAL MOTION.

2-10. PROJECTILE MOTION (STROBE PHOTOS) WITH SEPARATION OF MOTION HORIZONTALLY (CONSTANT VELOCITY) AND THE ACCELERATED VERTICAL MOTION.

CHAPTER 3 ILLUSTRATIONS

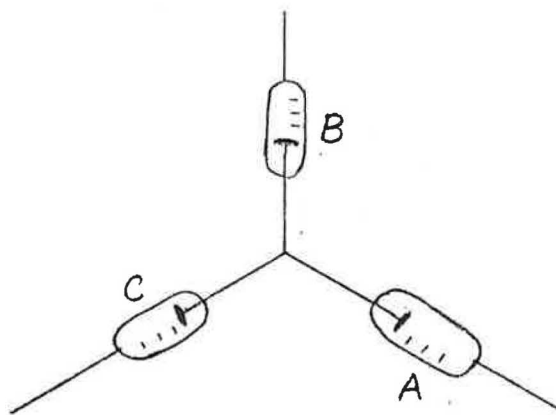

(a)

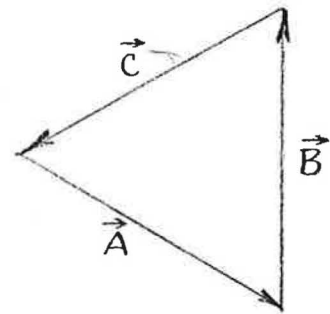

(b)

3-1. FORCES IN EQUILIBRIUM. (a) THREE SPRING BALANCES SHOWING FORCES (PHOTO). (b) VECTOR DIAGRAM OF THE THREE FORCES.

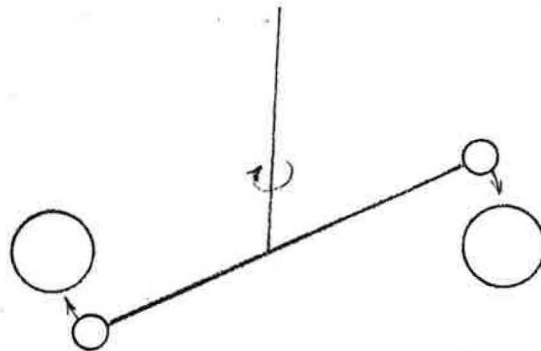

3-2. THE CAVENDISH BALANCE METHOD OF DETERMINING THE GRAVITATIONAL CONSTANT.

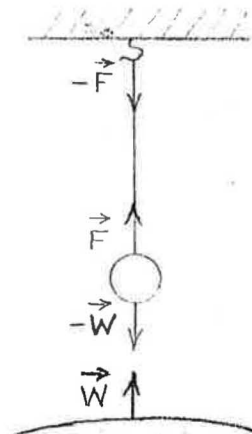
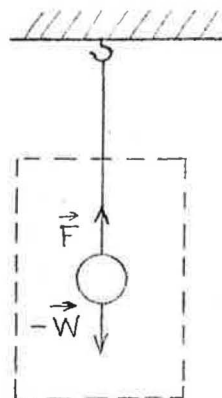

3-3. (a) FORCES ACTING ON A PENDULUM BOB AT REST. (b) ACTION-REACTION FORCE PAIRS.

CH. 3 ILLUS. (CONT.)

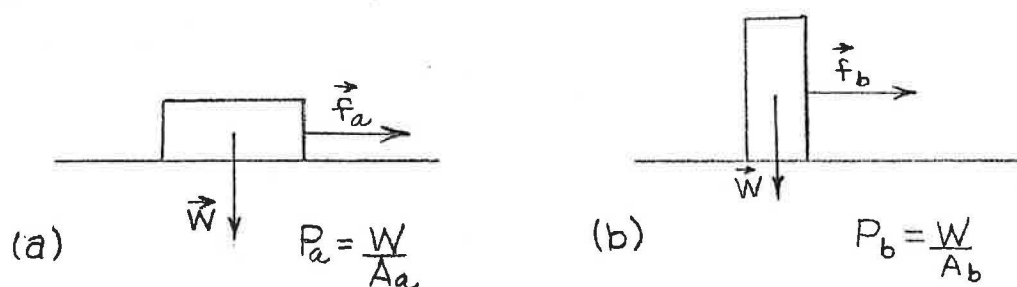

3-4. SLIDING FRICTION VECTORS FOR A BLOCK IN 2 ORIENTATIONS.

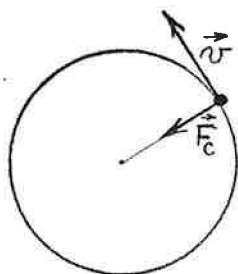

3-5. CENTRIPETAL FORCE REQUIRED TO MAINTAIN MOTION IN A CIRCULAR PATH

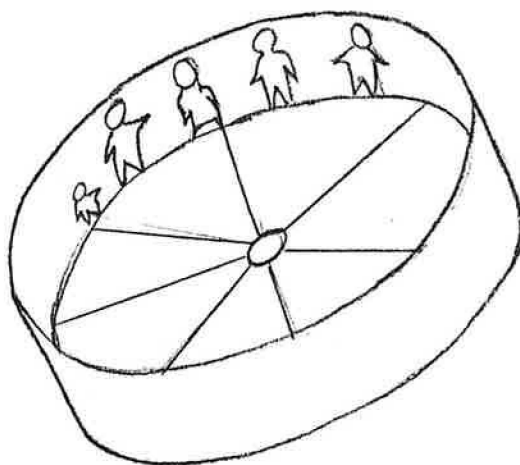

3-6. THE ROTOR RIDE — AN APPLICATION OF CENTRIPETAL FORCE. (PHOTO)

CH. 3 ILLUS. (CONT.)

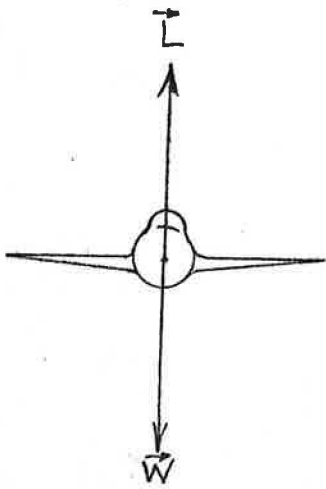

(a)

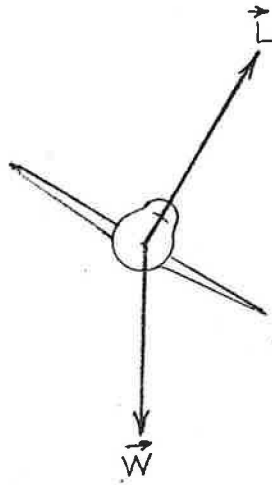

(b)

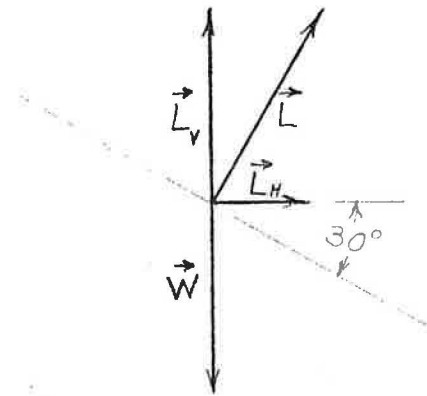

$$\vec{W} = 2400 \text{ LB}, L = 2800 \text{ LB}$$

$$L_v = 2400 \text{ LB}, L_h = 1200 \text{ LB}$$

(c)

3-7. WEIGHT AND LIFT VECTORS FOR A PLANE IN FLIGHT. (a) STRAIGHT AND LEVEL. (b) BANKED LEVEL. (c) VECTOR VALUES FOR EXAMPLE 3-8.

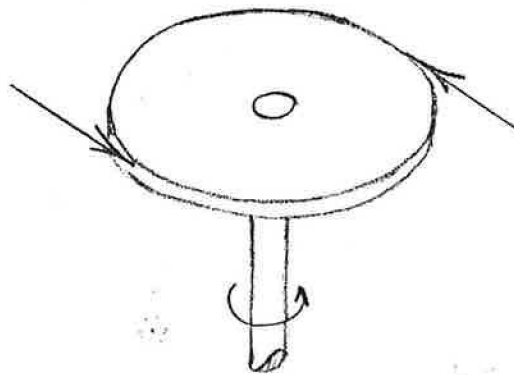

3-8. TORQUE ON A WHEEL WITH VERTICAL AXIS.

CH. 3 ILLUS. (CONT.)

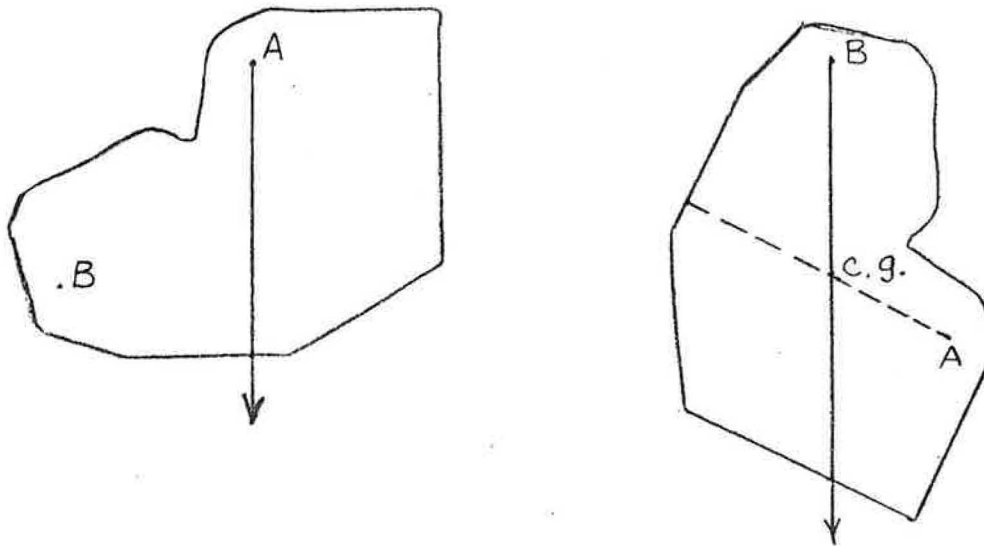

3-9. LOCATION OF THE c.g. OF AN IRREGULARLY-SHAPED OBJECT BY SUSPENSION FROM DIFFERENT POINTS.

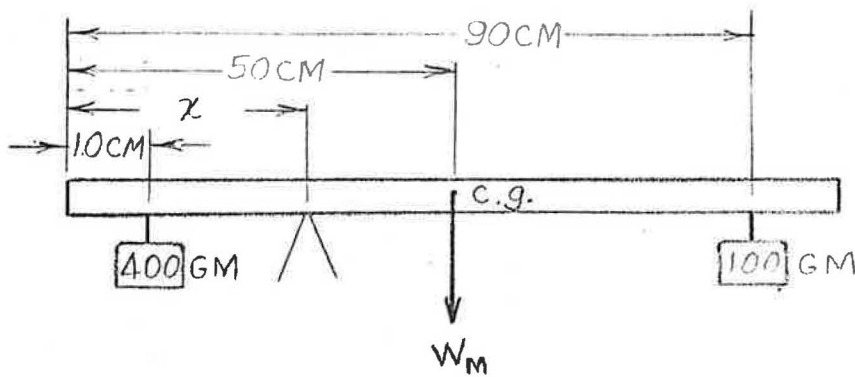

3-10. METER STICK SYSTEM IN EQUILIBRIUM.

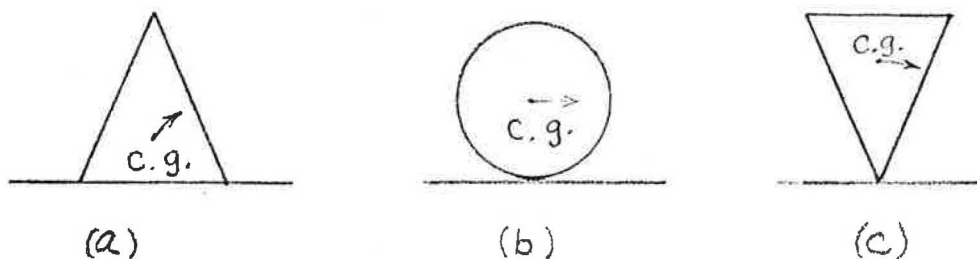

3-11. TYPES OF EQUILIBRIUM. (a) CONE IN STABLE CONDITION. (b) SPHERE IN NEUTRAL. (c) CONE UNSTABLE.

CHAPTER 4 ILLUSTRATIONS

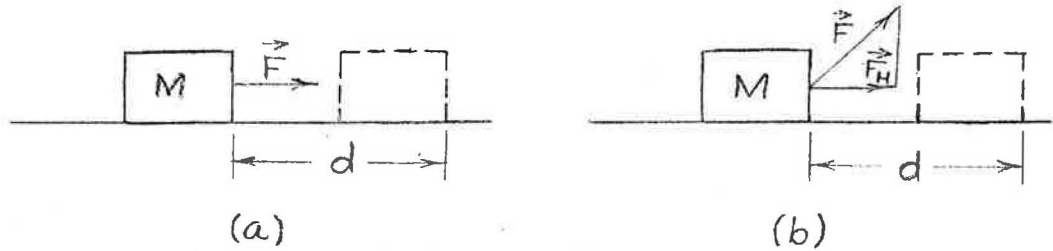

4-1. WORK DONE IN MOVING A BLOCK AGAINST FRICTION. (a) $WORK = F \times d$ (b) $WORK = F_H \cdot d$

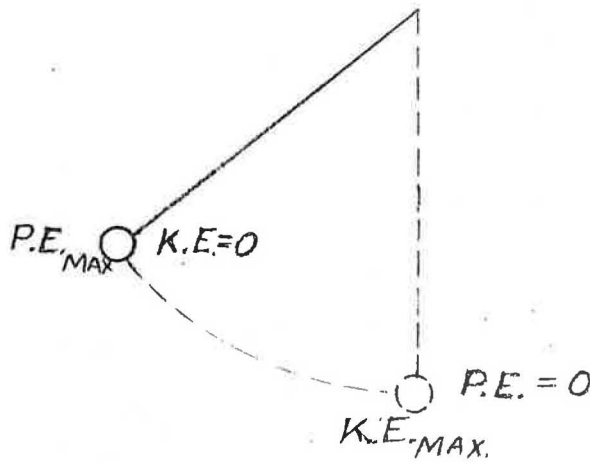

4-2. CONSERVATION OF ENERGY DURING THE SWING OF A SIMPLE PENDULUM: $P.E. + K.E. = \text{CONSTANT}$.

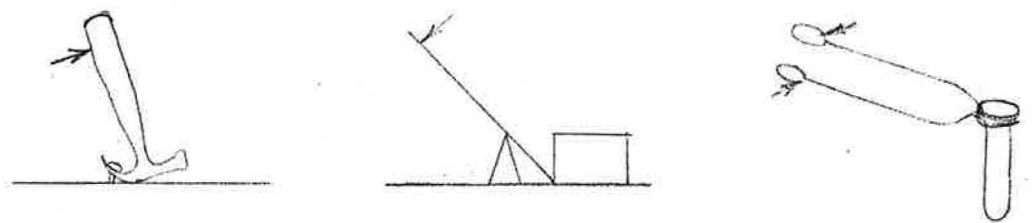

(a) HAMMER

(b) CROWBAR

(c) TONGS

4-3. EXAMPLES OF LEVERS. (PHOTOS)

CH. 4 ILLUS. (CONT.)

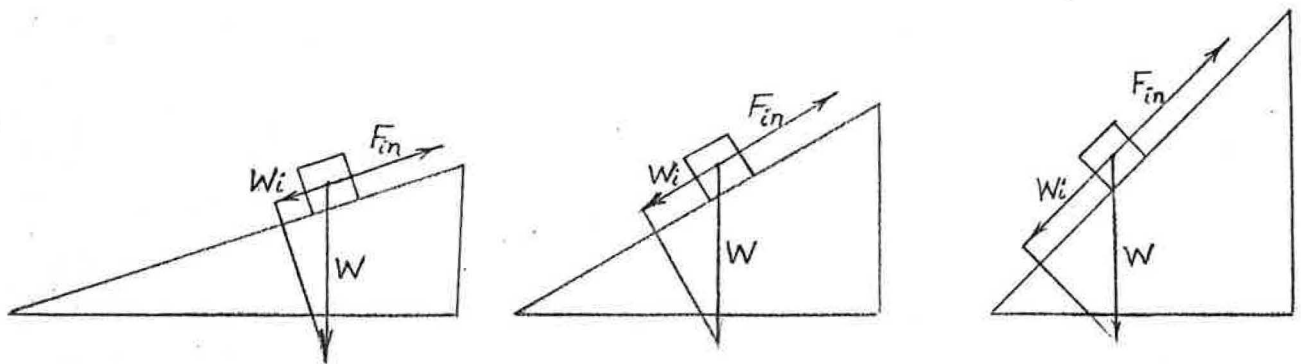

4-4 FORCE VECTORS FOR DIFFERENT INCLINE ANGLES. $F_{in} = W_i + f$ FOR EACH CASE.

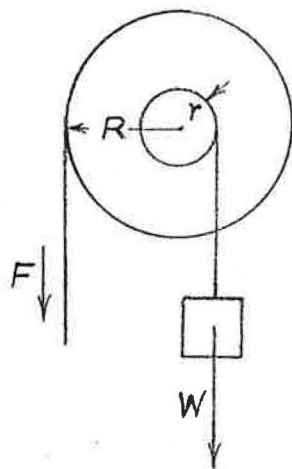

4-5. WHEEL AND AXLE

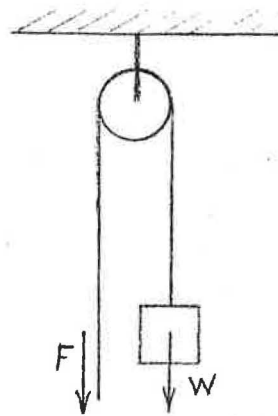

4-6 PULLEYS

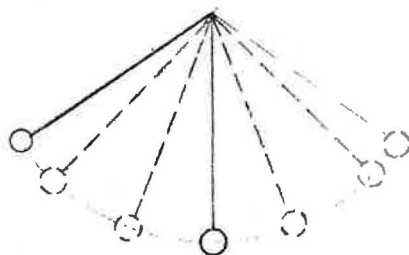
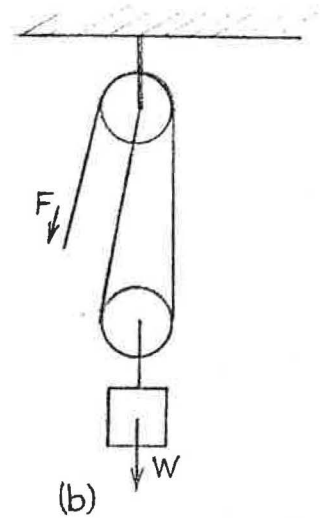

4-7. COLLISION OF EQUAL MASSES (STROBE PHOTO).

CHAPTER 5 ILLUSTRATIONS



5-1. LIQUID-IN-GLASS THERMOMETER (PHOTO).

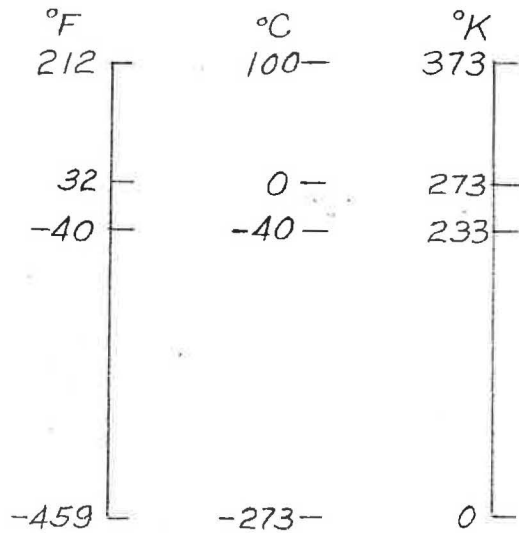

5-2. COMPARISON OF FAHRENHEIT, CELSIUS, AND KELVIN TEMPERATURE SCALES.

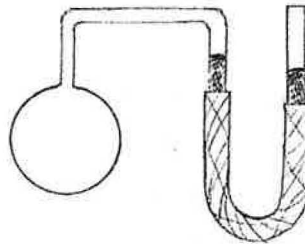

5-3. GAS THERMOMETER

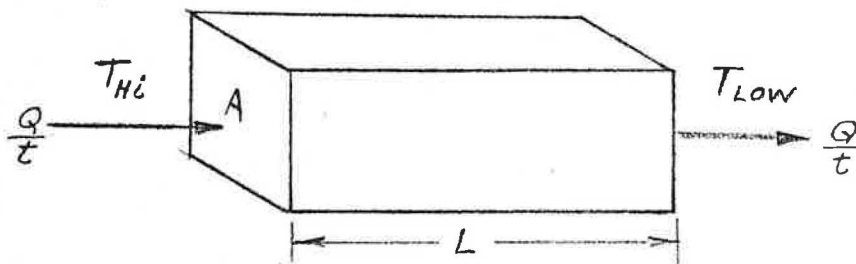

5-4. STEADY STATE HEAT FLOW THROUGH A CONDUCTOR.

CH. 5 ILLUS. (CONT.)

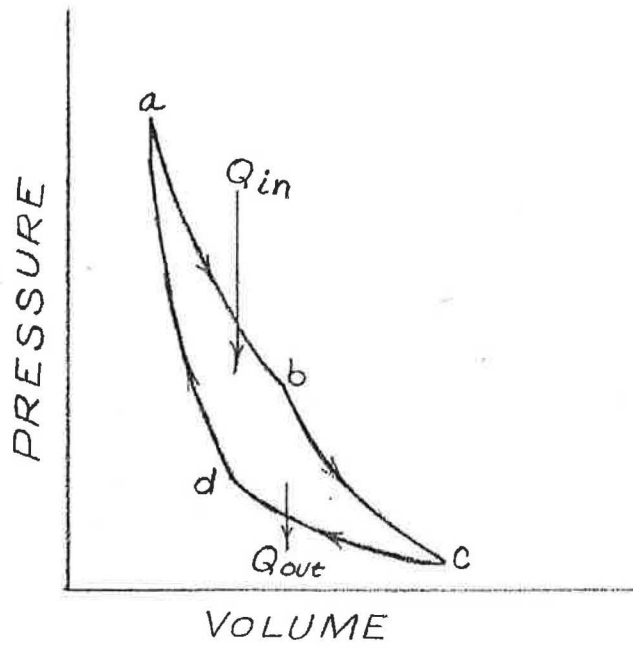

5-5. CARNOT CYCLE FOR AN
IDEAL GAS.

CHAPTER 6 ILLUSTRATIONS

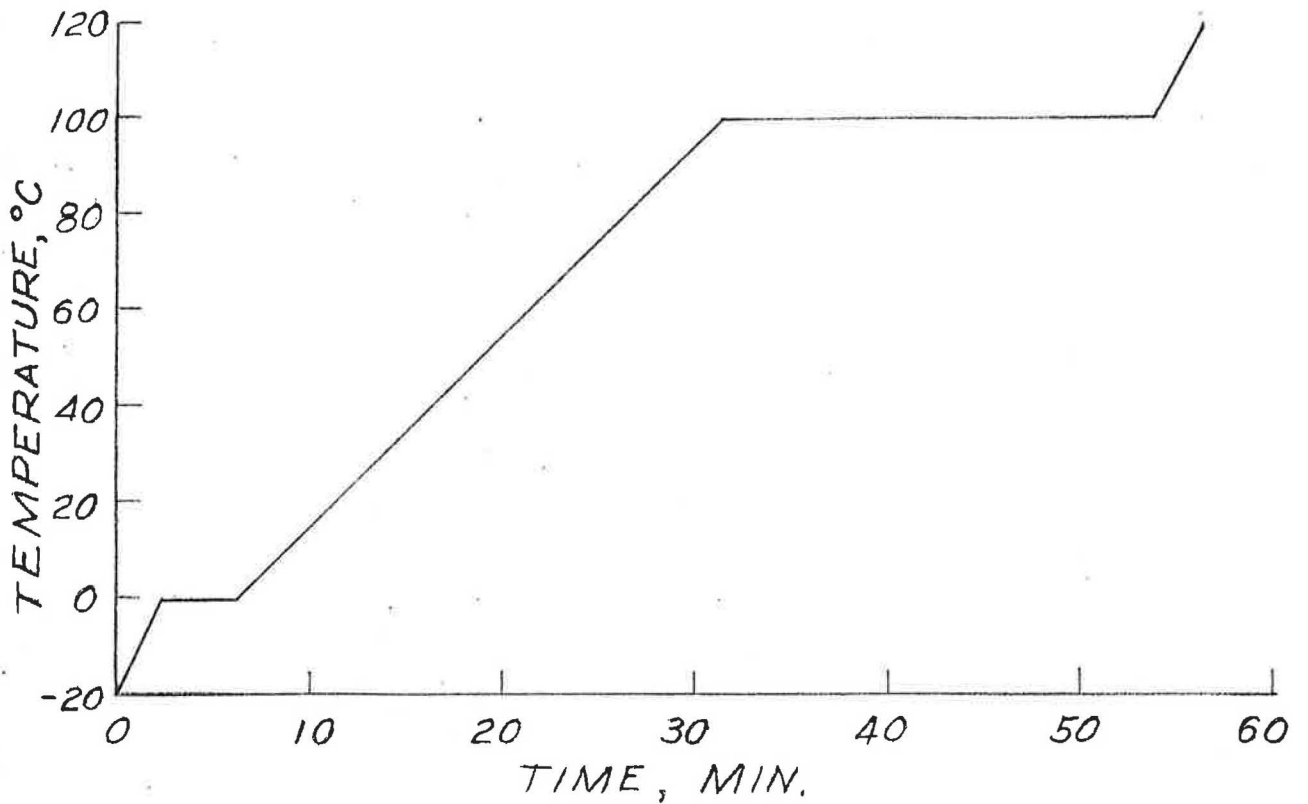

6-1. GRAPH OF TEMPERATURE CHANGE OF H_2O HEATED AT A CONSTANT RATE.

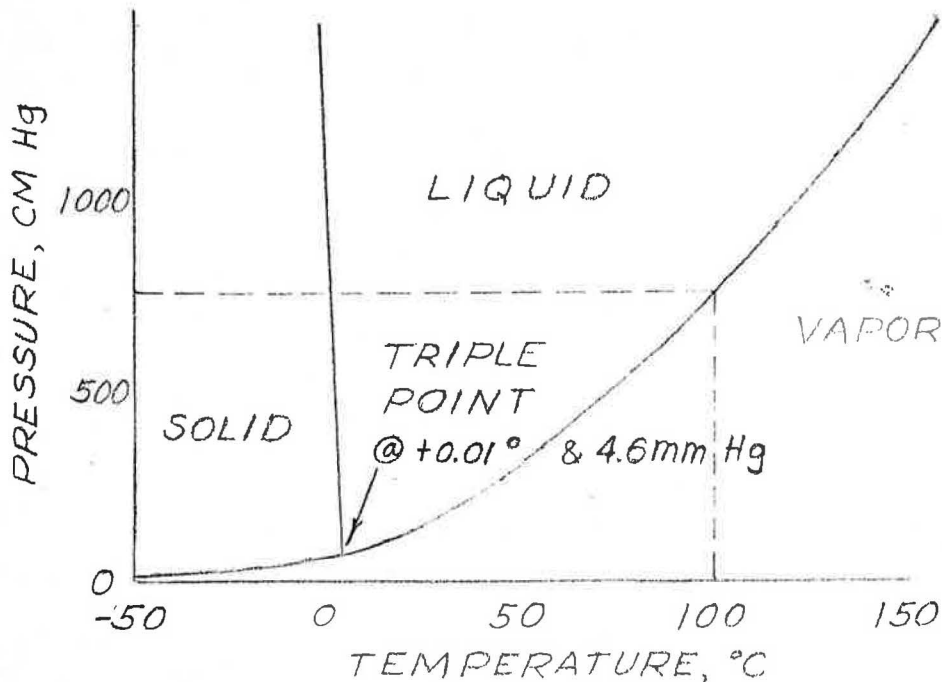

6-2. TRIPLE POINT DIAGRAM FOR H_2O .

CH. 6 ILLUS. (CONT.)

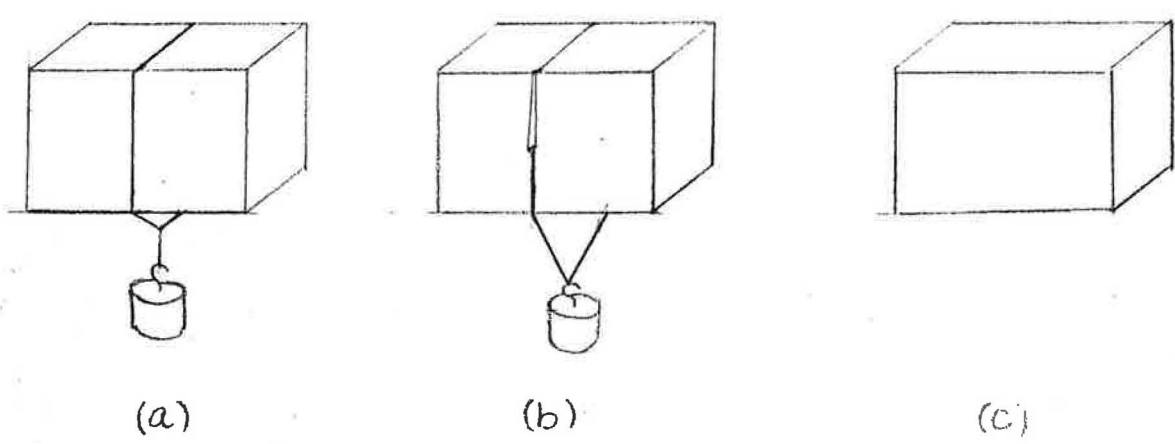

6-3. REGELATION IN AN ICE BLOCK (PHOTO).

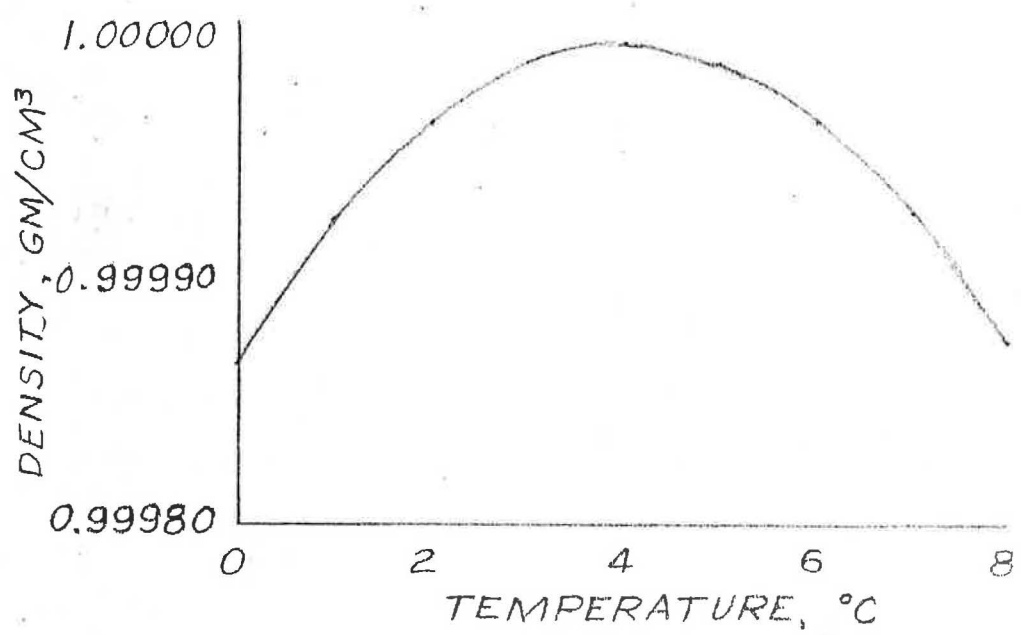

6-4. VARIATION OF WATER DENSITY WITH TEMPERATURE.

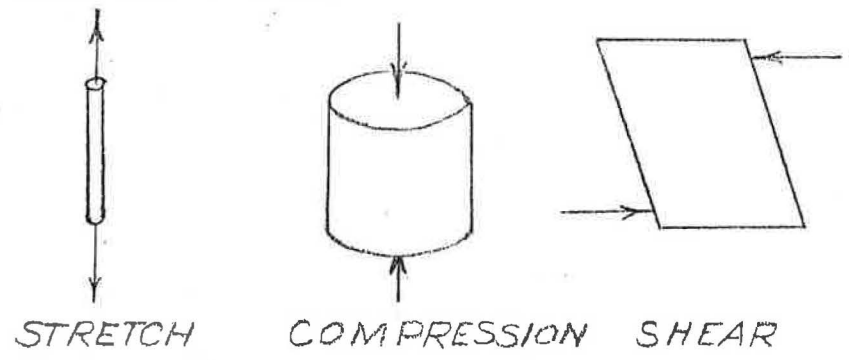

6-5. TYPES OF DEFORMATION OF SOLIDS.

CH. 6 ILLUS. (CONT.)

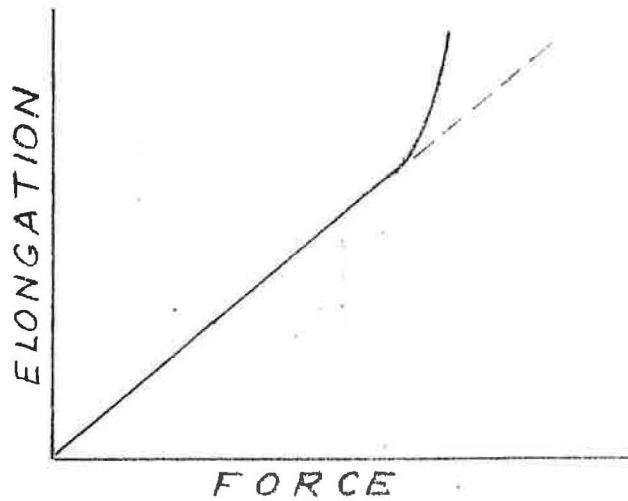

6-6. HOOKE'S LAW VARIATION OF STRAIN (ELONGATION) WITH STRESS (FORCE).

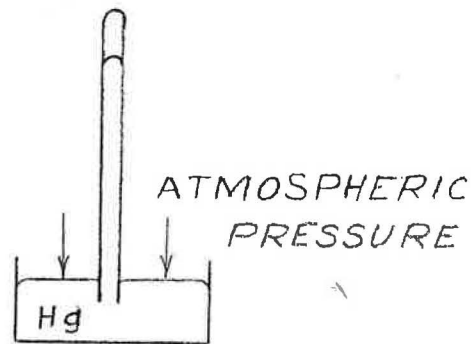

6-7. MERCURY BAROMETER

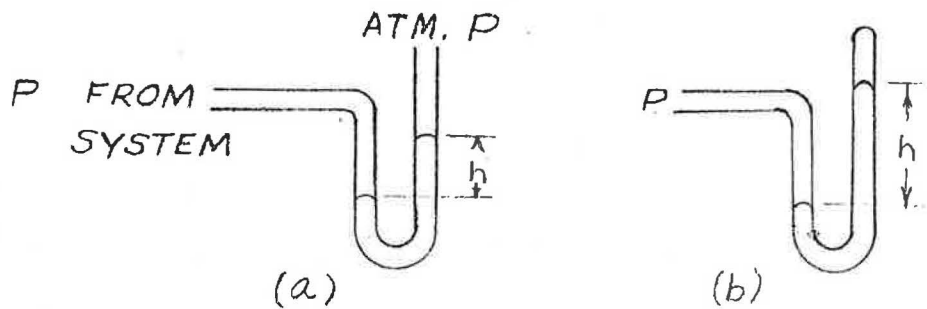

6-8 MERCURY MANOMETERS (a) OPEN TUBE (b) CLOSED TUBE

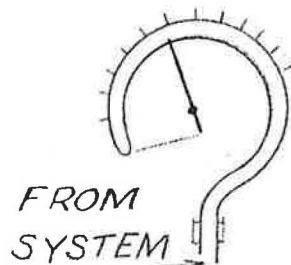

6-9. BOURDON PRESSURE GAUGE.

CHAPTER 7 ILLUSTRATIONS

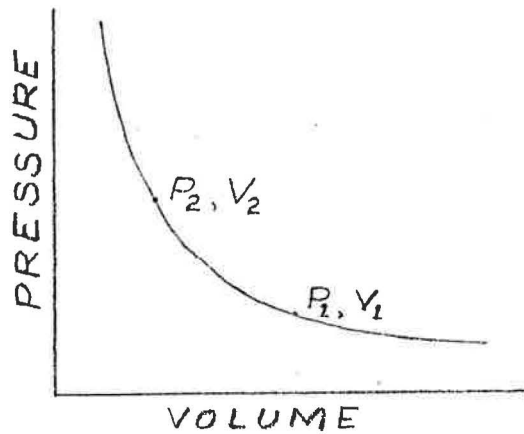

7-1. PRESSURE-VOLUME PLOT OF AN IDEAL GAS WHEN THE TEMPERATURE IS CONSTANT.

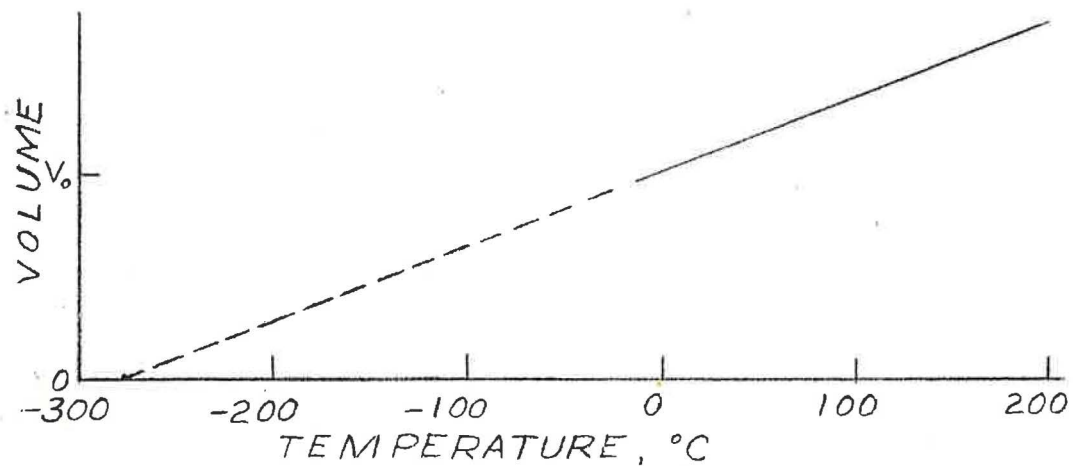

7-2. EXTRAPOLATION OF THE V-T PLOT OF A GAS TO A TEMPERATURE OF -273.15°C WHEN $V=0$.

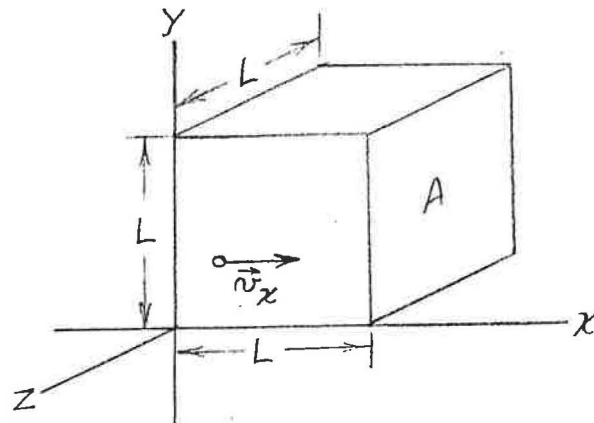

7-3. BOX CONTAINING N GAS MOLECULES.

CH. 7 ILLUS. (CONT.)

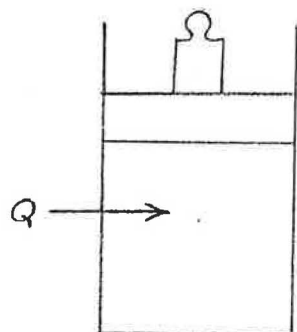

7-4. HEAT Q ADDED TO A GAS AT CONSTANT PRESSURE.

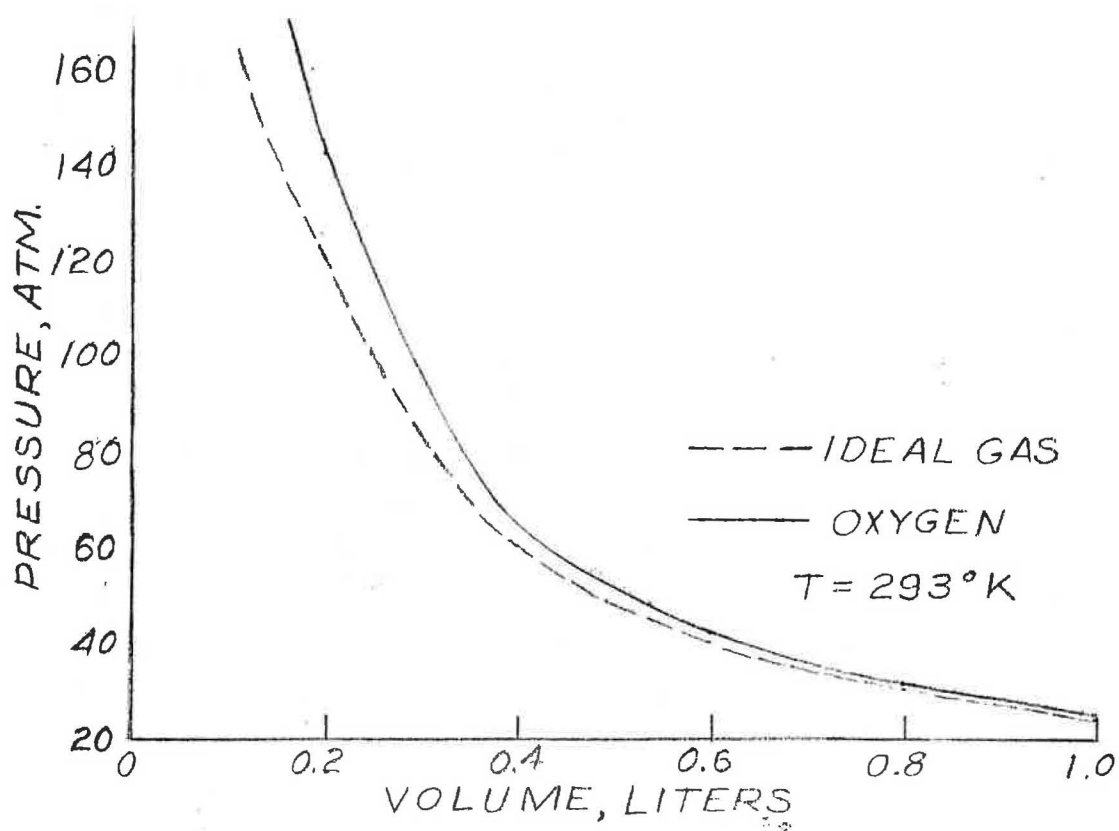

7-5. COMPARISON OF THE P - V CURVE FOR OXYGEN WITH THAT OF AN IDEAL GAS.

CHAPTER 8 ILLUSTRATIONS

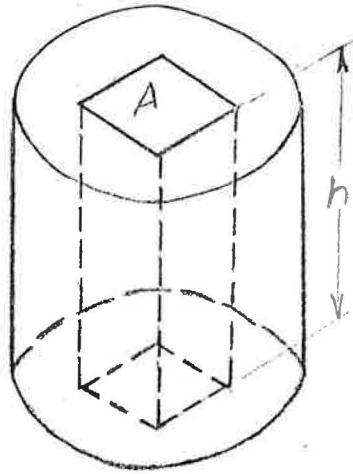

8-1. PRESSURE IN A FLUID.

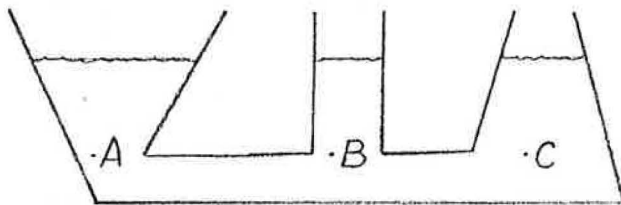

8-2. EQUAL PRESSURE AT EQUAL DEPTHS IN A LIQUID.

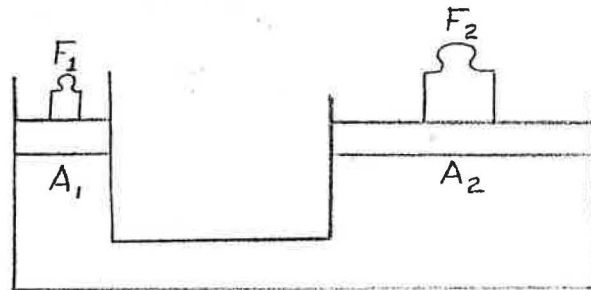

8-3. HYDRAULIC LIFT.

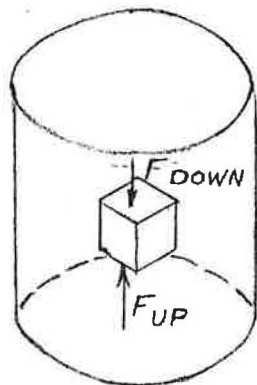

8-4. BUOYANT FORCE ON A CUBE IN A LIQUID.

CH. 8 ILLUS. (CONT.)

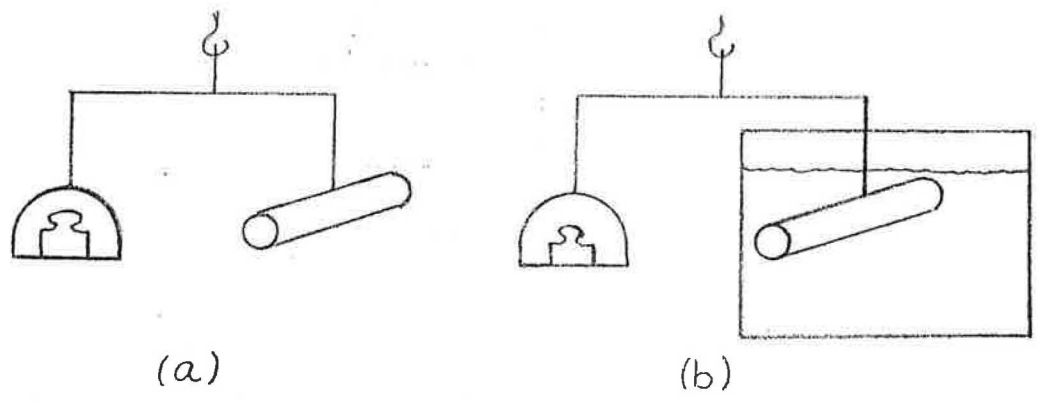

8-5. EXPERIMENTAL ARRANGEMENT FOR EXAMPLE 8-2.

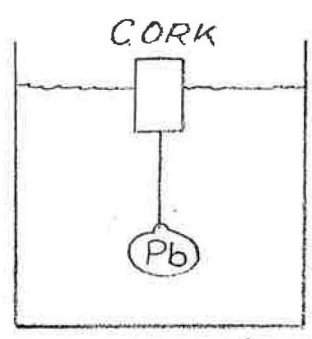

8-6. FLOATING CORK AND SINKER FOR EXAMPLE 8-4.

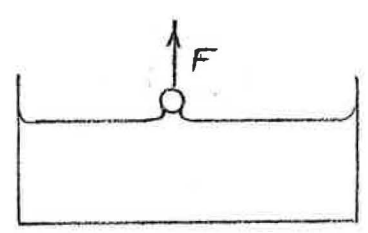

8-7. FORCE REQUIRED TO ENLARGE SURFACE AREA.



8-8. EFFECT OF GRAVITY ON DIFFERENT SIZED DROPS. (PHOTO).

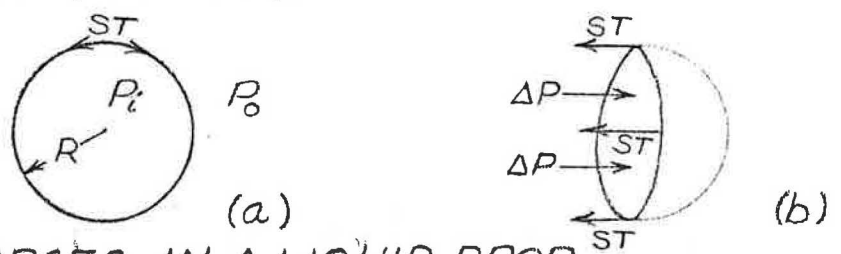

8-9. FORCES IN A LIQUID DROP.

CH 8 ILLUS. (CONT.)

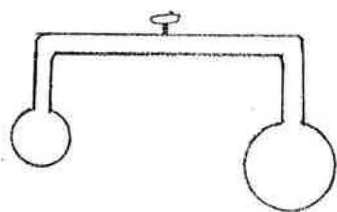

(a)

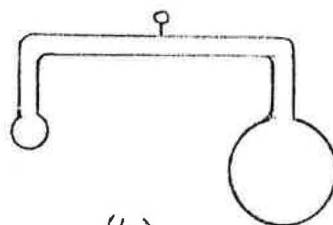

(b)

8-10. PRESSURE RELATIONS IN BUBBLES (PHOTO).

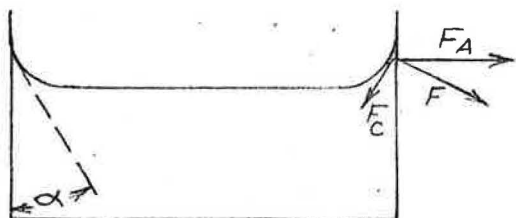

(a)

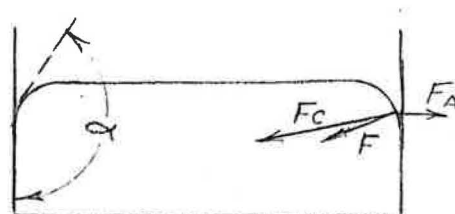

(b)

8-11. LIQUID-SOLID INTERFACES. (a) WATER AND GLASS.

(b) MERCURY AND GLASS.

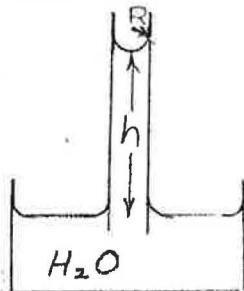

8-12. GLASS CAPILLARY TUBE. (DIMENSIONS EXAGGERATED)

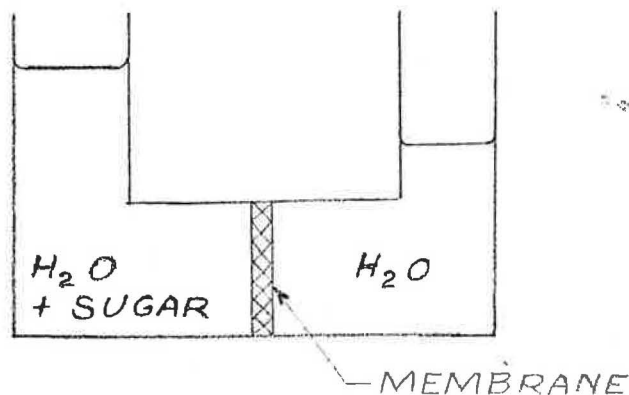

8-13. OSMOSIS

CHAPTER 9 ILLUSTRATIONS

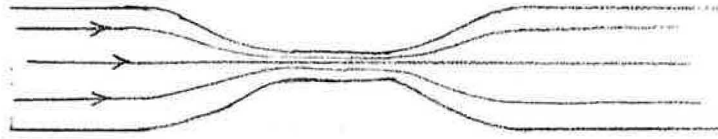

9-1. STREAMLINE FLOW THROUGH A CONSTRICTION.

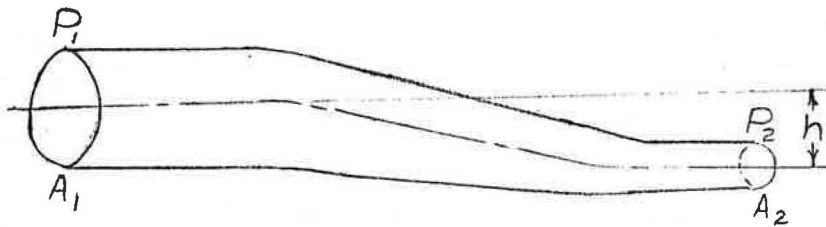

9-2. FLUID FLOW SYSTEM FOR APPLICATION OF BERNOULLI'S PRINCIPLE.

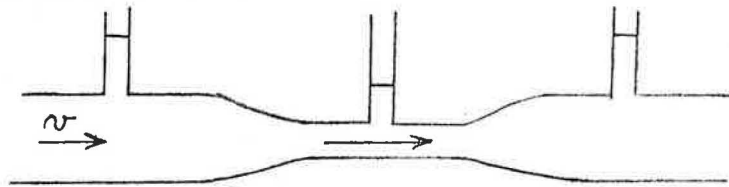

9-3. PRESSURE AND VELOCITY RELATIONS FOR LIQUID FLOW IN A TUBE.

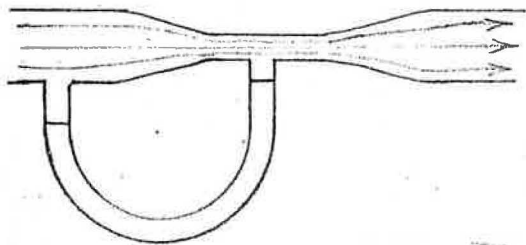

(a) VENTURI METER

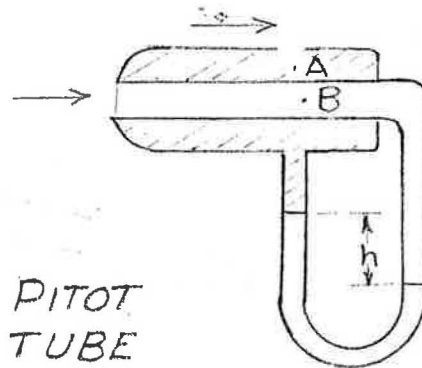

(b) PITOT TUBE

9-4. TWO DEVICES FOR MEASURING GAS SPEED BY APPLICATION OF THE BERNOULLI EQUATION.

CH. 9 ILLUS. (CONT.)

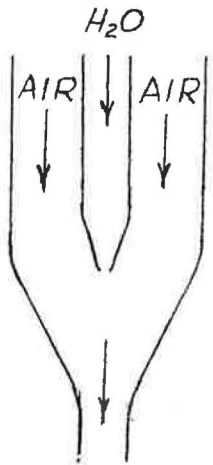

(a) WATER PUMP

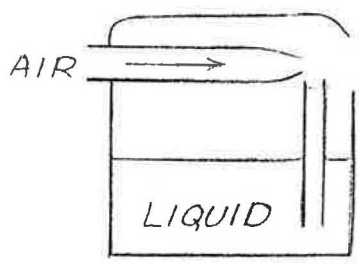

(b) NEBULIZER

9-5.

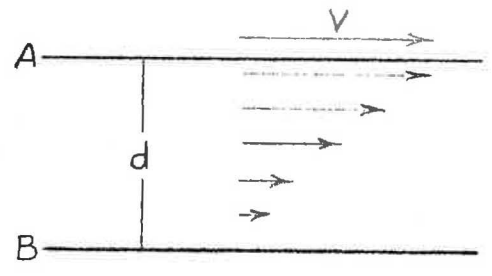

9-6. DISTRIBUTION OF FLUID VELOCITIES BETWEEN TWO PLATES.

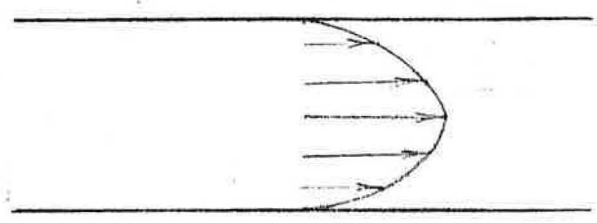

9-7. FLOW VELOCITIES OF A REAL FLUID IN A PIPE,

CH. 9 ILLUS. (CONT.)

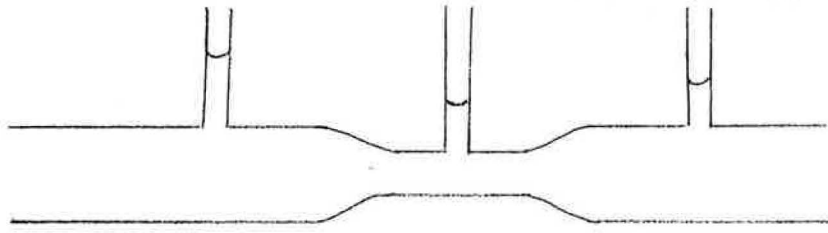

9-8. HEAD OR LOSS OF LIQUID FLOWING THROUGH A PIPE. (PHOTO).

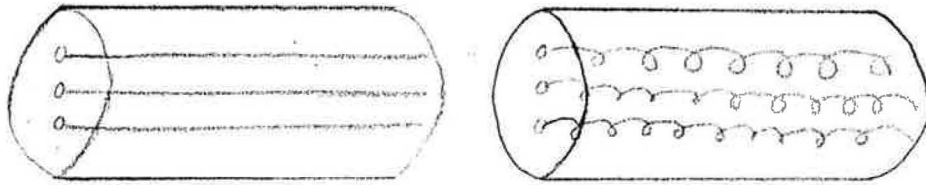

(a) LAMINAR

(b) TURBULENT

9-9. TYPES OF FLUID FLOW. (PHOTO).

CHAPTER 10 ILLUSTRATIONS

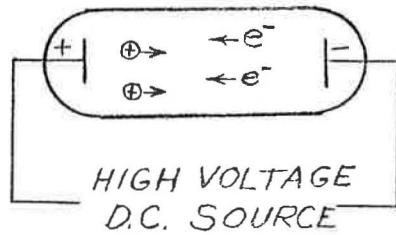

10-1 COLD CATHODE RAY TUBE.

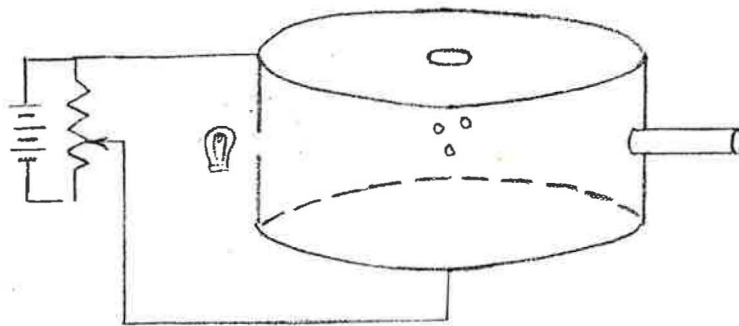

10-2 MILLIKAN OIL DROP APPARATUS.

LEVEL	ENERGY
n	0
3	-1.5
2	-3.4

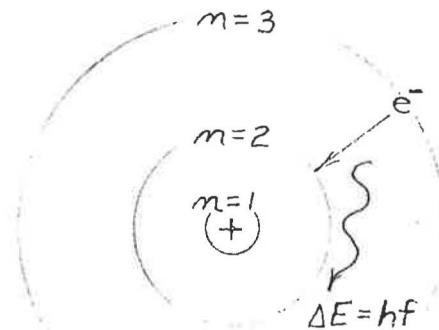

1 ——— -13.6 eV

(a) ENERGY LEVELS

(b) ORBITS WITH RADIUS $\propto n^2$

10-3. BOHR MODEL OF A HYDROGEN ATOM.

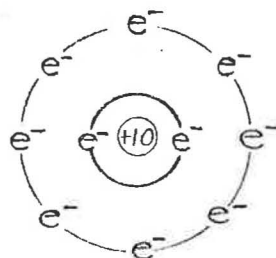

10-4. SHELLS OF AN INERT GAS (NEON).

CH. 10 ILLUS. (CONT.)

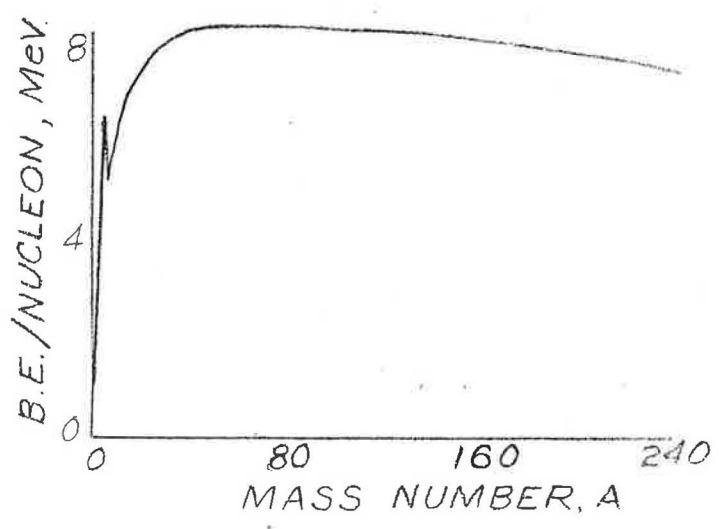

10-5. BINDING ENERGY PER NUCLEON FOR NUCLEI OF DIFFERENT MASS NUMBERS.

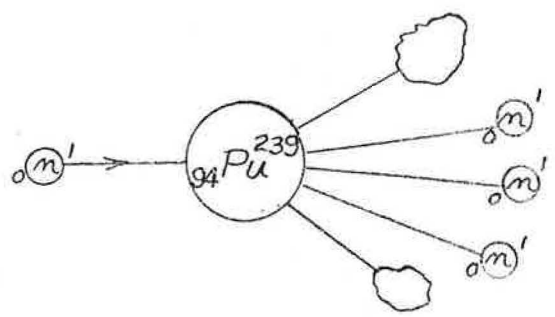

10-6. FISSION OF A PLUTONIUM NUCLEUS WHEN STRUCK BY A THERMAL NEUTRON.

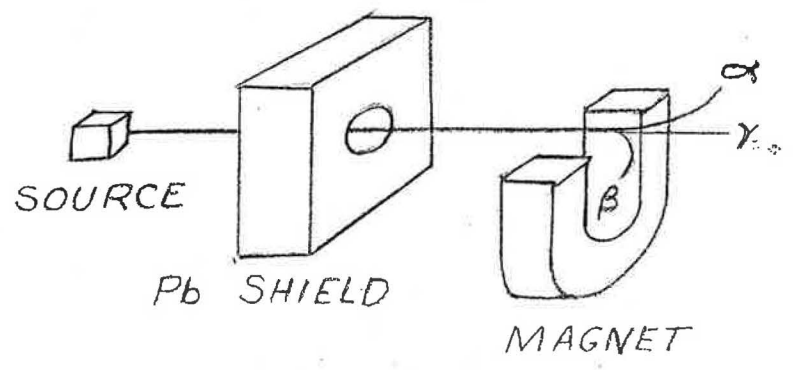

10-7. SEPARATION OF THE RADIATION FROM A RADIOACTIVE SOURCE.

CH. 10 ILLUS. (CONT.)

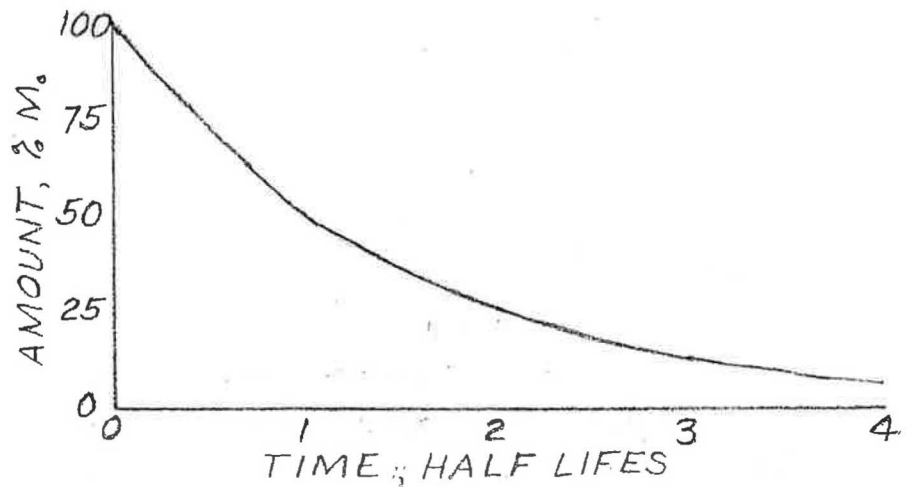

10-9. EXPONENTIAL DECAY PLOT OF A RADIOISOTOPE.

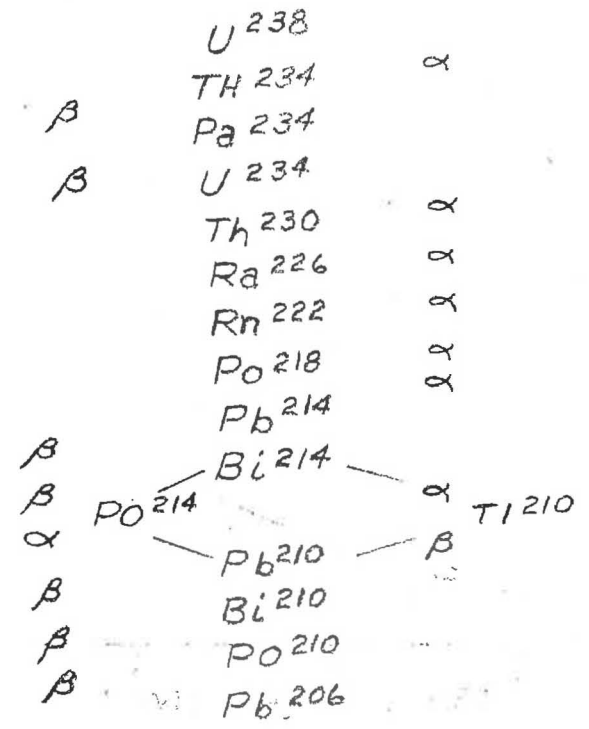

10-10. RADIOACTIVE DECAY CHAIN FROM URANIUM-238 TO THE STABLE ISOTOPE OF LEAD 206. TWO MODES OF DECAY ARE POSSIBLE FROM BISMUTH 214 TO LEAD 210.

CH. 10 ILLUS. (CONT.)

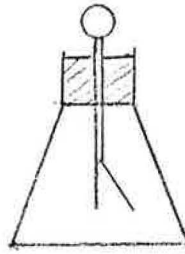

10-11. CHARGED ELECTROSCOPE.

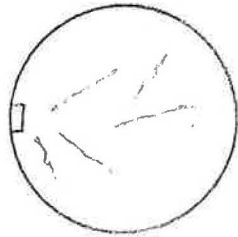

10-12. CLOUD CHAMBER TRACKS. (PHOTO)

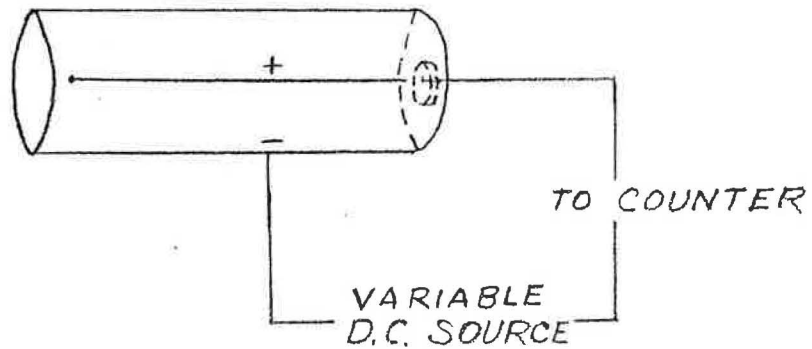

10-13. GEIGER TUBE DIAGRAM.

CHAPTER 11 ILLUSTRATIONS



11-1. ELECTROSTATIC FORCES. (a) ATTRACTION OF UNLIKE CHARGES. (b) REPULSION OF LIKE CHARGES. (PHOTO)

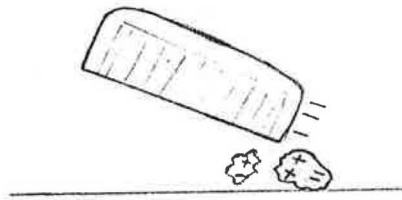

11-2. ATTRACTION OF SMALL NEUTRAL OBJECTS (PAPER) BY A CHARGED OBJECT. (PHOTO)

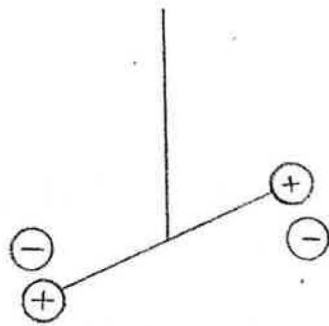

11-3. TORSION BALANCE FOR DETERMINING ELECTROSTATIC FORCE.

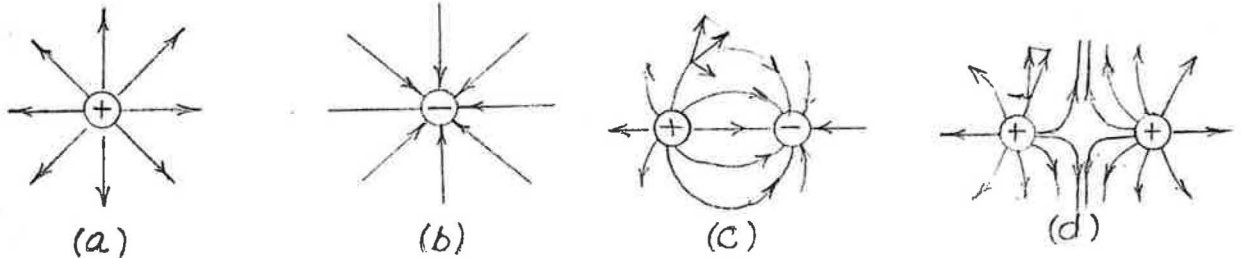

11-4. ELECTROSTATIC FORCE FIELDS.

CH. 11 ILLUS. (CONT.)

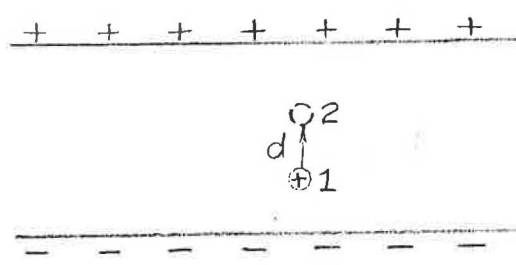





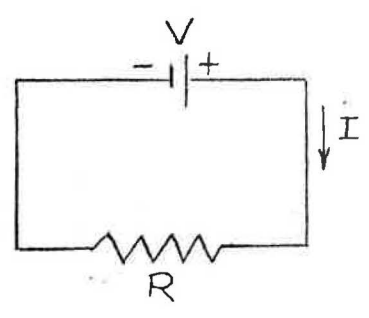

$$P.D. = \frac{W}{q} = \frac{E \times d}{q}$$

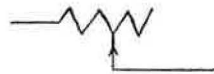
11-5. POTENTIAL DIFFERENCE BETWEEN POINT 1 AND 2 IN TERMS OF THE WORK/CHARGE.

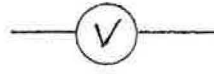

(a)

-  VARIABLE RESISTANCE
-  BATTERY
-  SWITCH
-  AMMETER
-  VOLTMETER
-  GALVANOMETER

(b)

11-6. SIMPLE ELECTRICAL CIRCUIT DIAGRAM AND SYMBOLS USED FOR COMPONENTS OF CIRCUITS.

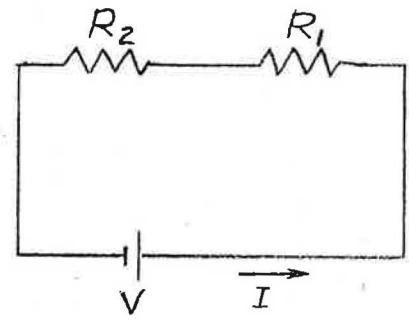

(a)

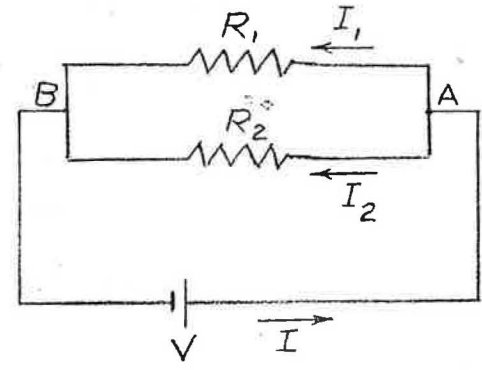

(b)

11-7. RESISTANCE CIRCUITS. (a) SERIES (b) PARALLEL.

CH. II ILLUS. (CONT.)

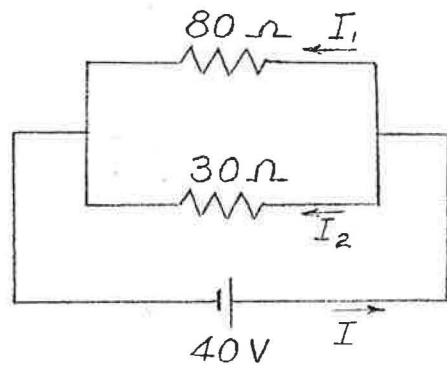

11-8. DIAGRAM FOR EXAMPLE 11-10.

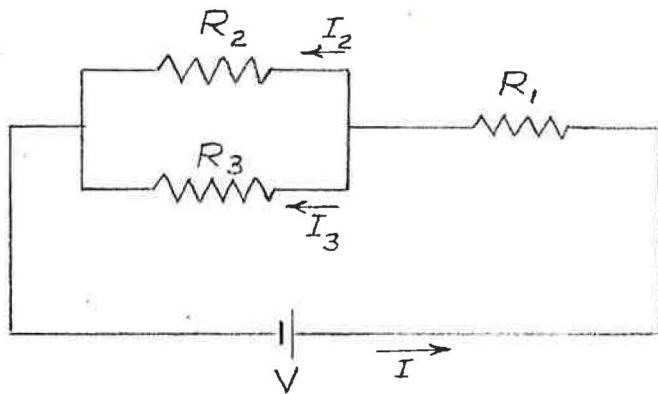

11-9. DIAGRAM FOR EXAMPLE 11-11.

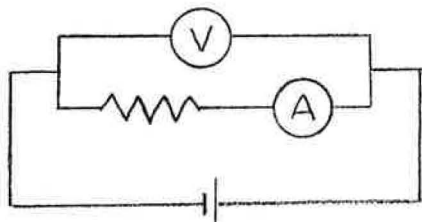

(a)

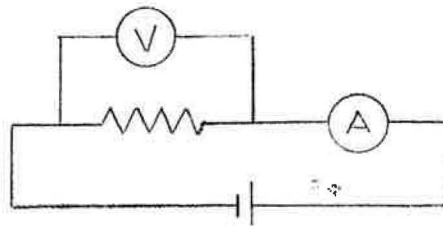

(b)

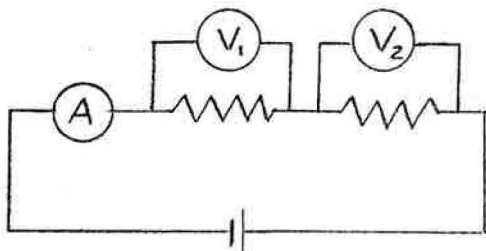

(c)

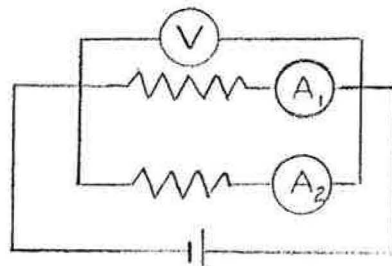

(d)

11-10. METER ARRANGEMENTS FOR MEASURING I AND V.

CH. 11 ILLUS. (CONT.)

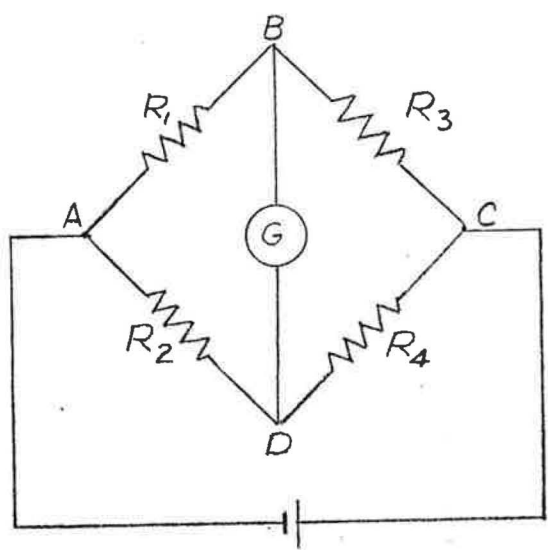

11-11. THE WHEATSTONE BRIDGE FOR MEASURING RESISTANCE.

CHAPTER 12 ILLUSTRATIONS

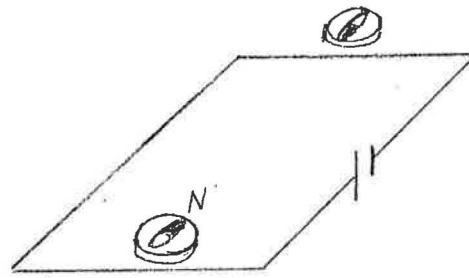

12-1. EFFECT ON COMPASSES OF NEARBY CURRENT,

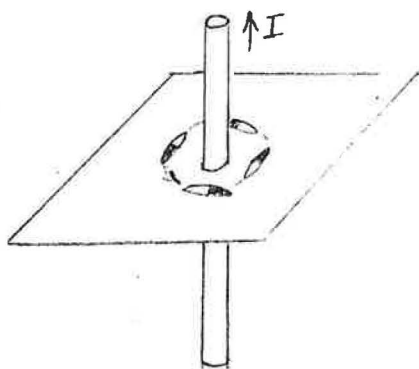

(a) WITH COMPASSES

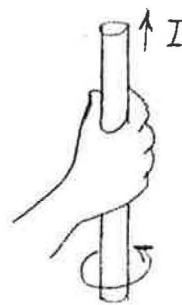

(b) RIGHT HAND RULE

12-2. MAGNETIC FIELD DIRECTION.



(a)

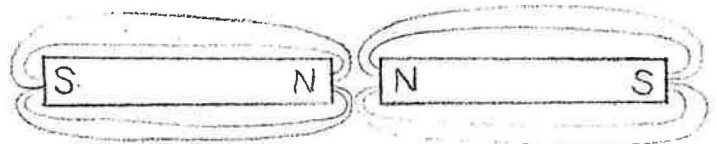

(b)



(c)



(d)

12-3. MAGNETIC FIELDS AROUND BAR MAGNETS (PHOTOS WITH IRON FILINGS).

CH. II ILLUS. (CONT.)

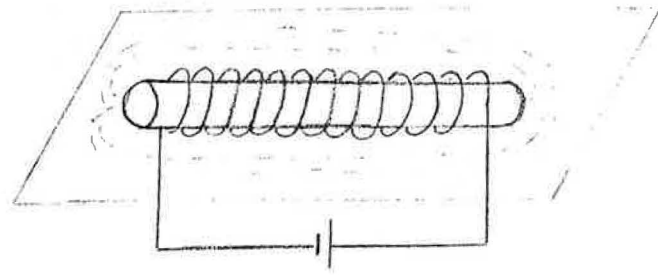

12-4. MAGNETIC FIELD SURROUNDING A CURRENT-CARRYING SOLENOID (PHOTO).



(a)

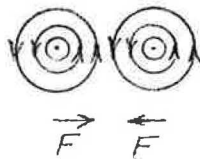

(b)

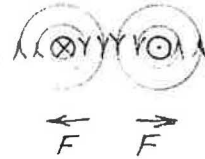

(c)

12-5. MAGNETIC FIELDS SURROUNDING CURRENT-CARRYING WIRES.

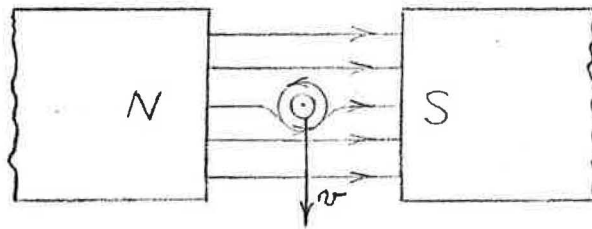

12-6. CURRENT INDUCED IN A CONDUCTOR MOVING ACROSS A MAGNETIC FIELD.

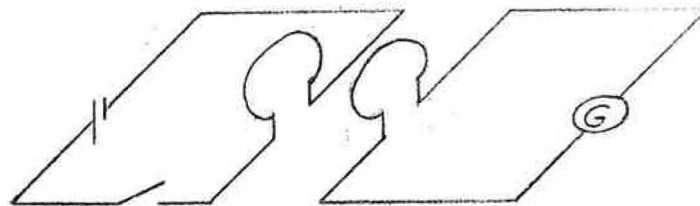

12-7. MUTUAL INDUCTION IN WIRE LOOPS.

CH. 12 ILLUS. (CONT.)

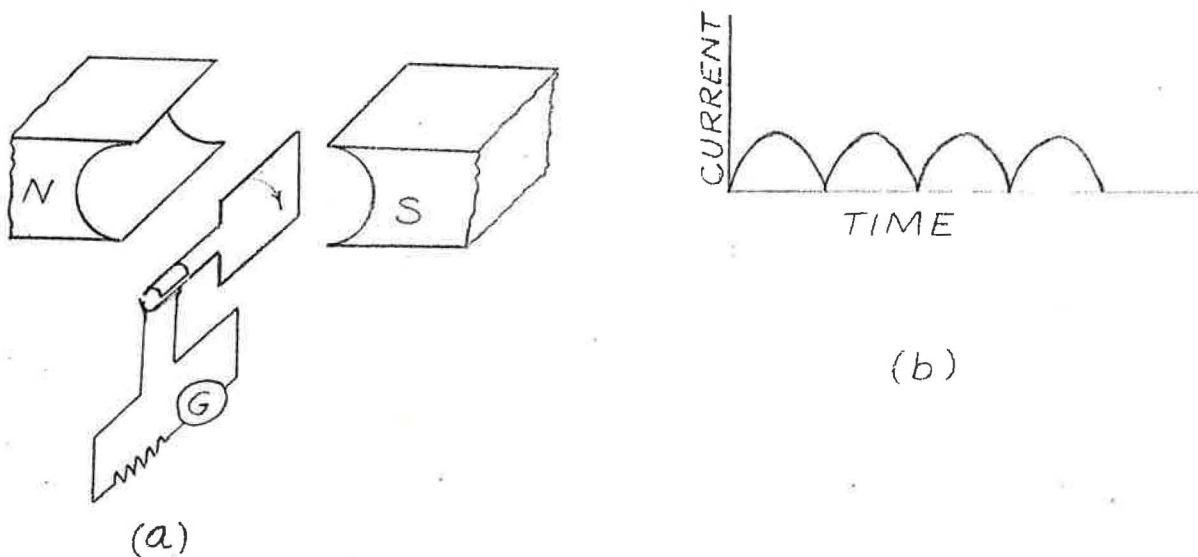

12-11. SCHEMATIC DIAGRAM OF D-C GENERATOR AND PULSATING CURRENT OUTPUT.

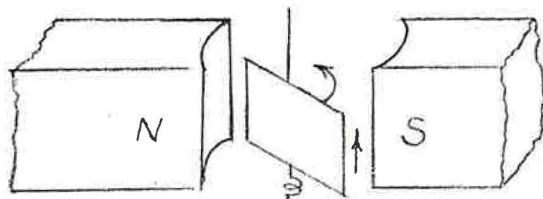

12-12. MOVING COIL GALVANOMETER.

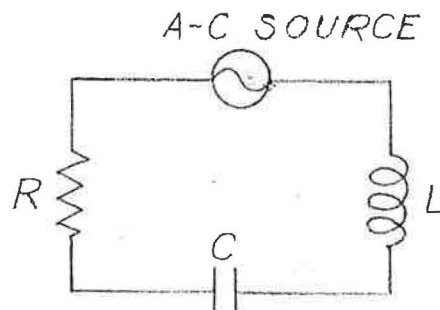
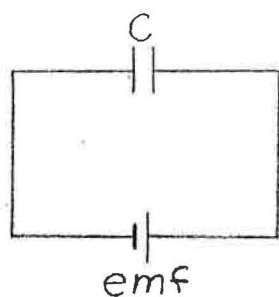

12-13. (a) D-C CIRCUIT WITH A CAPACITOR. (b) A-C CIRCUIT WITH CAPACITOR, RESISTANCE, AND INDUCTANCE.

CH. 12 ILLUS. (CONT.)

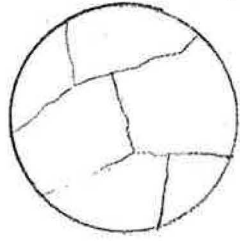

12-8. MAGNETIC DOMAINS IN A FERROMAGNETIC MATERIAL. (PHOTO).

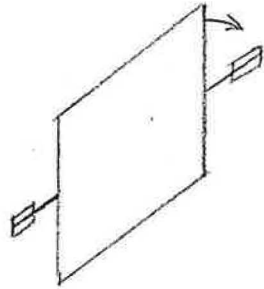

12-9. GENERATING emf BY A COIL CUTTING THROUGH THE MAGNETIC FIELD OF THE EARTH. (PHOTO).

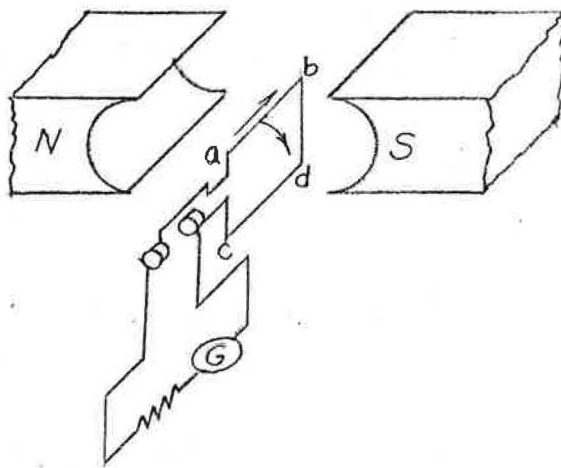

(a)

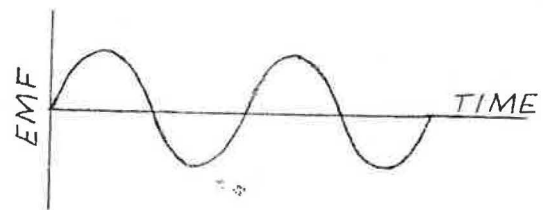

(b)

12-10. SCHEMATIC DIAGRAM OF A-C GENERATOR AND OUTPUT VOLTAGE VARIATION WITH TIME.

CH. 12 ILLUS. (CONT.)

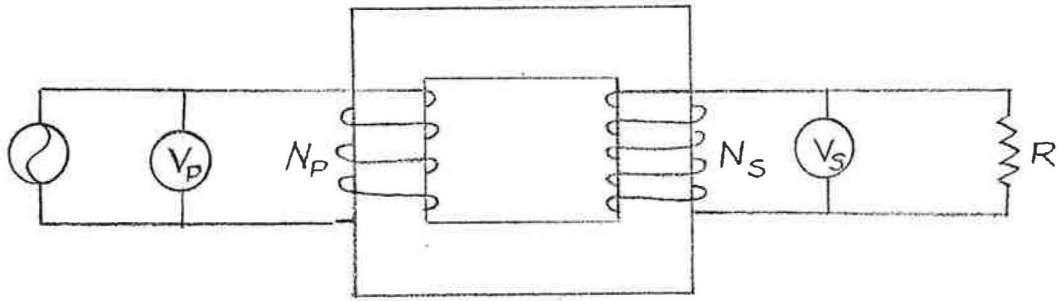

12-14. IRON-CORE TRANSFORMER CIRCUIT.

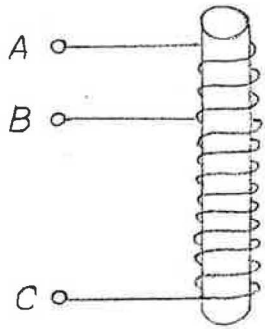

12-15. AUTOTRANSFORMER.

CHAPTER 13 ILLUSTRATIONS

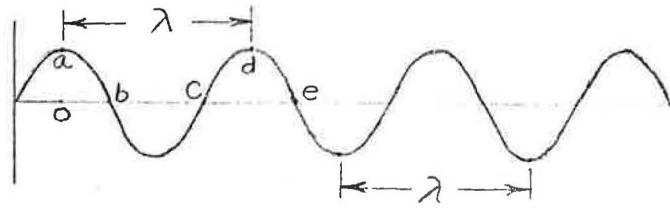

13-1. TRANSVERSE WAVE FORM.



13-2. WAVE PULSE (a) TRAVELING TO RIGHT IN A LIGHT WEIGHT CORD (b) REFLECTED PULSE WITH 180° PHASE CHANGE.

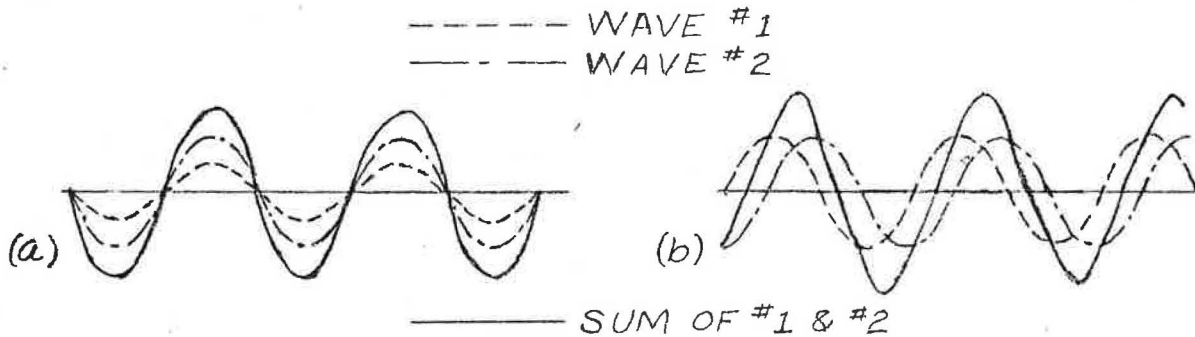

13-3. SUPERPOSITION OF TWO WAVES (a) IN PHASE (b) 90° OUT-OF-PHASE.

CHAP. 13 ILLUS. (CONT.)

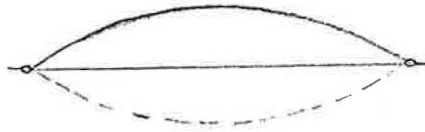

13-4. STANDING WAVE ON STRING (STROBE PHOTO).



13-5. DIFFRACTION OF MONOCHROMATIC (LASER) LIGHT PASSING THROUGH A SMALL OPENING (PHOTO).

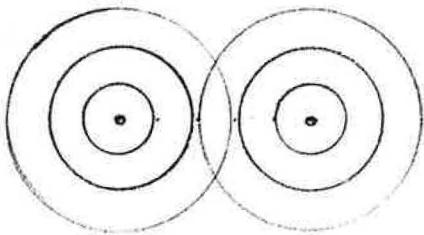

(a)

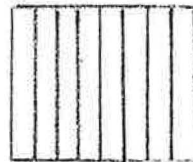

(b)

13-6. INTERFERENCE OF WAVES (a) FROM 2 SOURCES IN WATER (b) FROM LASER LIGHT PASSING THROUGH 2 SLITS. (PHOTOS).

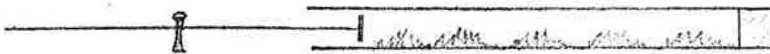

13-7. STANDING WAVES IN AIR SHOWN BY CORK DUST PATTERNS IN THE KUNDT'S TUBE. (PHOTO).

CHAP. 13 ILLUS. (CONT.)

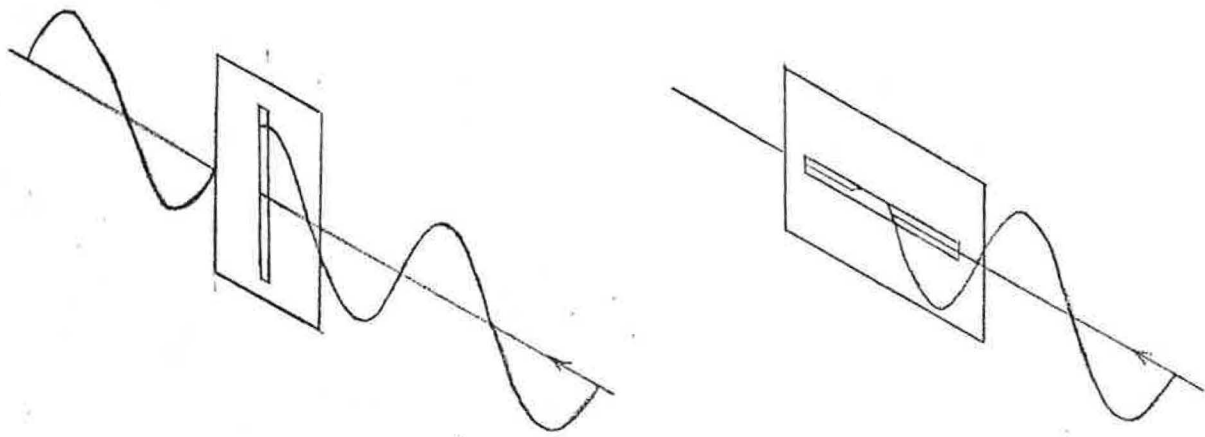

13-8. EFFECT OF SLITS ON TRANSMISSION OF TRANSVERSE WAVES

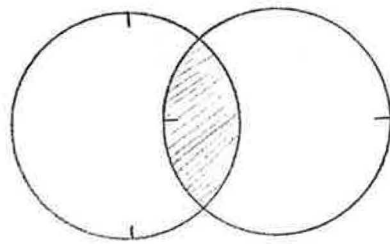

13-9. EFFECT OF CROSSED POLARIDS ON THE TRANSMISSION OF LIGHT (PHOTO).